

P-14763-2

S4540

21641

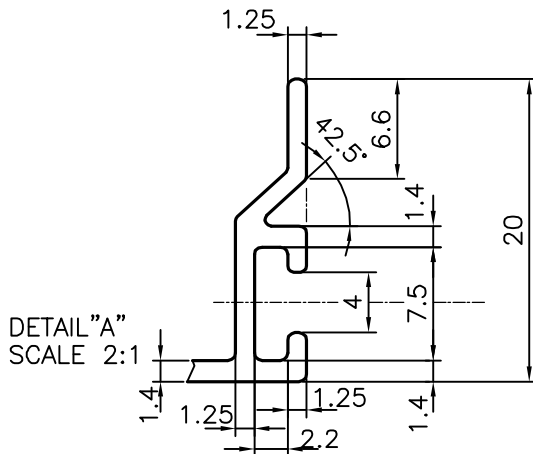
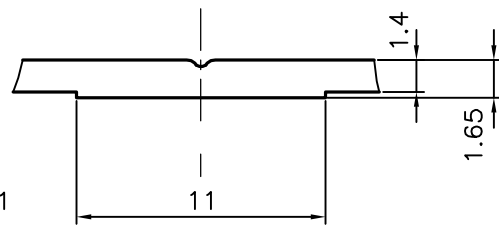
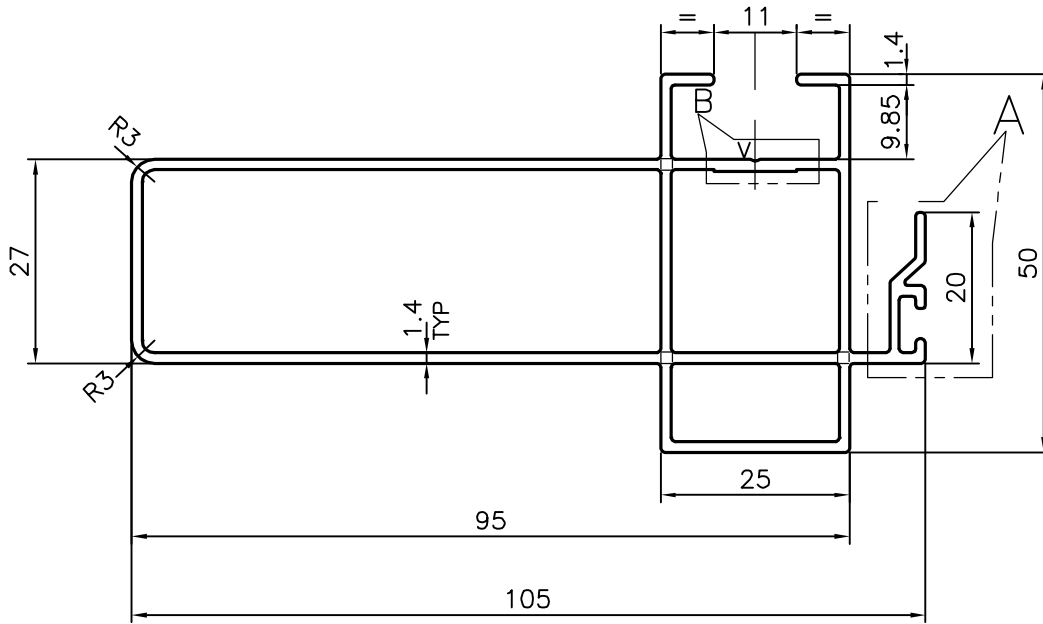

UNSPECIFIED RADII 0.5 mm

V = V GROOVE 0.3x90°



SYMBOL OF QUALITY  
AN ISO 9001 COMPANY

**JINDAL ALUMINIUM LTD.**  
BANGALORE-560073 (INDIA)

	NAME	DATE
DRAWN	J.P.KAUSHIK	23-06-2015
CHECKED		
APPROVED	B.NATARAJA	21-07-2015
SCALE		1:1
AREA mm <sup>2</sup>		527.664
PERIMETER mm.		399.248
WEIGHT kg/m		1.425
DRAWING No.	SECTION No.	
P-14763-2		
S4540	S4540	
21641	21641	

1. ALL DIMENSIONS ARE IN mm.
2. ROUND OFF ALL SHARP CORNERS WITH 0.40 mm.
3. TOLERANCES WILL BE AS PER IS:6477-1983 UNLESS OTHERWISE SPECIFIED

PARTY'S NAME	HATIM GLAZING & CLADDING PVT. LTD., MUMBAI
PARTY'S DRAWING No.	AS PER DRAWING & REQUIREMENT
ALLOY & TEMPER	6063 T5
DESCRIPTION	WINDOW SECTION