

P-15326

21643

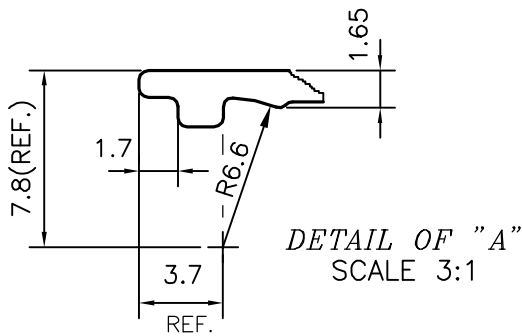
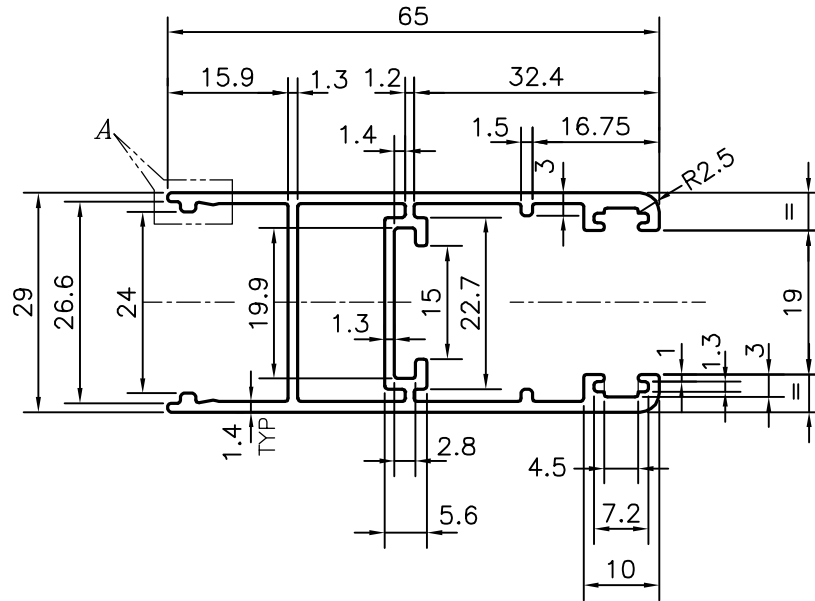
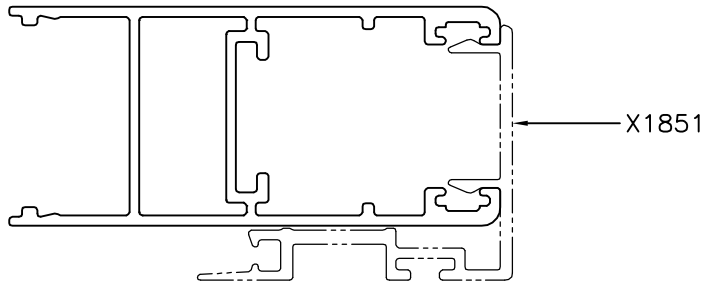

SYMBOL OF QUALITY
AN ISO 9001 COMPANY

JINDAL ALUMINIUM LTD.
BANGALORE-560073 (INDIA)

	NAME	DATE
DRAWN	J.P.KAUSHIK	18-11-2015
CHECKED		
APPROVED	S.S.GARG	23-11-2015
SCALE		1:1
AREA	mm ²	313.123
PERIMETER	mm.	342.23
WEIGHT	kg/m	0.845
DRAWING No.	SECTION No.	
P-15326	-	
21643	21643	

1. ALL DIMENSIONS ARE IN mm.
2. ROUND OFF ALL SHARP CORNERS WITH 0.40 mm.
3. TOLERANCES WILL BE AS PER IS:6477-1983 , UNLESS OTHERWISE SPECIFIED

PARTY'S NAME	GENERAL CATEGORY, AHMEDABAD MARKET
PARTY'S DRAWING No.	MODIFIED OF SECTION No:- X1850
ALLOY & TEMPER	HE9 WP
DESCRIPTION	WINDOW SECTION