

P-15327

21644

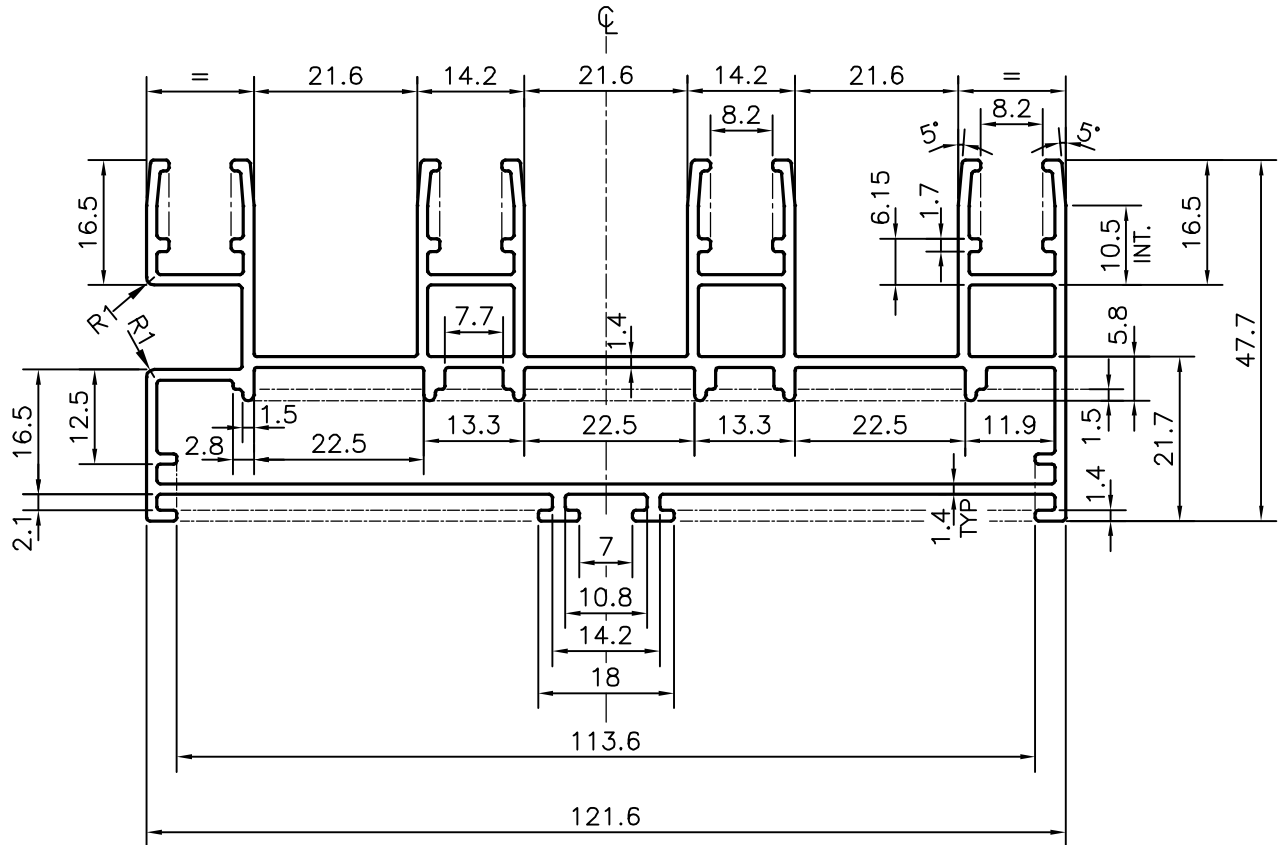

SYMBOL OF QUALITY
AN ISO 9001 COMPANY

JINDAL ALUMINIUM LTD.
BANGALORE-560073 (INDIA)

	NAME	DATE
DRAWN	J.P.KAUSHIK	18-11-2015
CHECKED		
APPROVED	S.S.GARG	23-11-2015
SCALE		1:1
AREA mm ²		865.64
PERIMETER mm.		712.72
WEIGHT kg/m		2.337
DRAWING No.	SECTION No.	
P-15327	-	
21644	21644	

1. ALL DIMENSIONS ARE IN mm.
2. ROUND OFF ALL SHARP CORNERS WITH 0.40 mm.
3. TOLERANCES WILL BE AS PER IS:6477-1983 , UNLESS OTHERWISE SPECIFIED

PARTY'S NAME	GENERAL CATEGORY, AHMEDABAD MARKET
PARTY'S DRAWING No.	AS PER X1849 & REQUIREMENT
ALLOY & TEMPER	HE9 WP
DESCRIPTION	WINDOW SECTION