

P-15394-1

21648

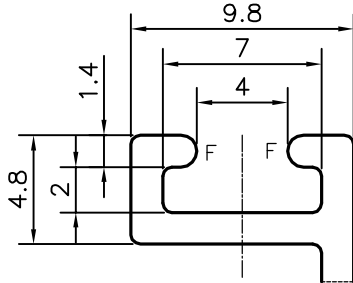

DETAIL OF "A"
SCALE 3:1

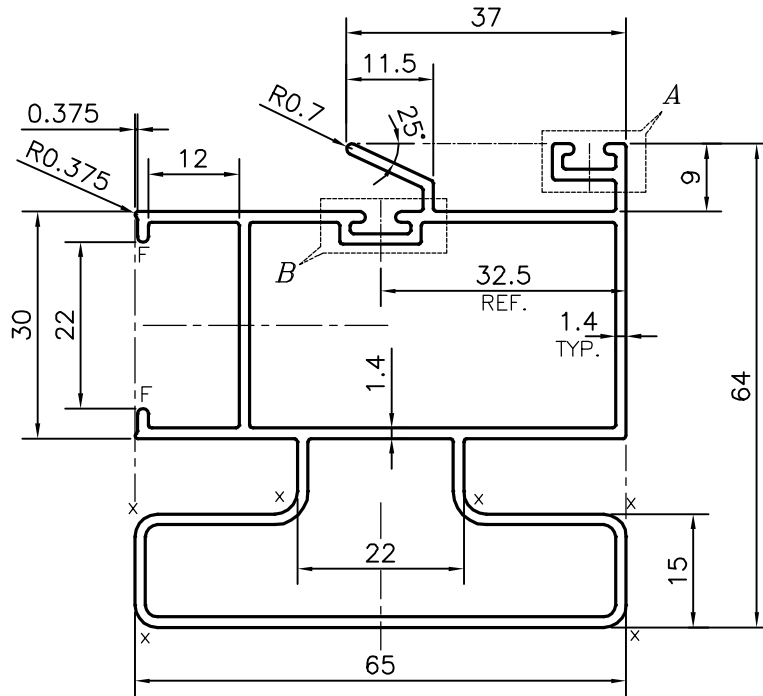
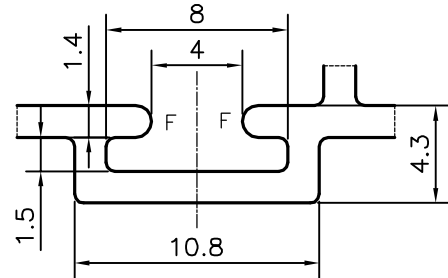

DETAIL OF "A"
SCALE 3:1

F = FULL RADIUS (6 PLACES)
X = RADIUS 3 mm. (6 PLACES)



SYMBOL OF QUALITY
AN ISO 9001 COMPANY

JINDAL ALUMINIUM LTD.
BANGALORE-560073 (INDIA)

	NAME	DATE
DRAWN	PARVESH	14-12-2015
CHECKED		
APPROVED	S.S.GARG	01-01-2016
SCALE		1:1
AREA mm ²		540.025
PERIMETER mm.		439.593
WEIGHT kg/m		1.458
DRAWING No.	SECTION No.	
P-15394-1	-	
21648	21648	

1. ALL DIMENSIONS ARE IN mm.
2. ROUND OFF ALL SHARP CORNERS WITH 0.40 mm.
3. TOLERANCES WILL BE AS PER IS:6477-1983 , UNLESS OTHERWISE SPECIFIED

PARTY'S NAME	GENERAL CATEGORY, MUMBAI MARKET
PARTY'S DRAWING No.	AS PER AUTOCAD DRAWING & REQUIREMENT
ALLOY & TEMPER	HE9 WP
DESCRIPTION	WINDOW SECTION