

P-10809-2

S2954

21655

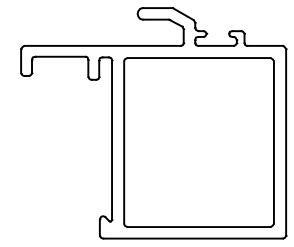
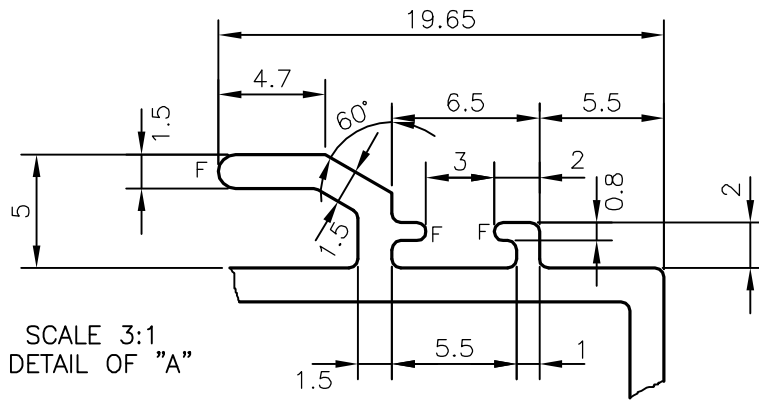

SCALE 3:1
DETAIL OF "A"

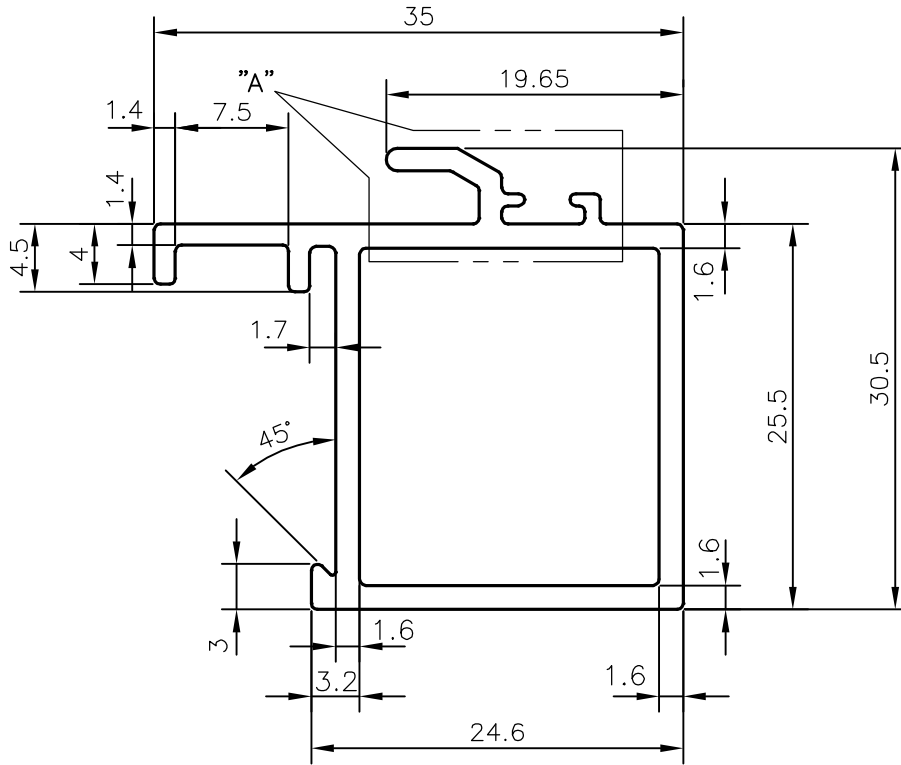

F= FULL RADIUS (3 PLACES)



SYMBOL OF QUALITY
AN ISO 9001 COMPANY

JINDAL ALUMINIUM LTD.
BANGALORE-560073 (INDIA)

| | NAME | DATE |
|----------------------|-------------|------------|
| DRAWN | J.P.KAUSHIK | 07-05-2011 |
| CHECKED | | |
| APPROVED | S.S.GARG | 09-06-2011 |
| SCALE | | 2:1 |
| AREA mm ² | | 194.81 |
| PERIMETER mm. | | 160.599 |
| WEIGHT kg/m | | 0.526 |
| DRAWING No. | SECTION No. | |
| P-10809-2 | - | |
| S2954 | S2954 | |
| 21655 | 21655 | |

1. ALL DIMENSIONS ARE IN mm.
2. ROUND OFF ALL SHARP CORNERS WITH 0.40 mm.
3. TOLERANCES WILL BE AS PER IS:6477-1983 UNLESS OTHERWISE SPECIFIED

| | |
|---------------------|-----------------------------|
| PARTY'S NAME | DG-MAP, NEW DELHI |
| PARTY'S DRAWING No. | DGM-07 |
| ALLOY & TEMPER | HE9 WP |
| DESCRIPTION | WINDOW SECTION (INTER LOCK) |