

P-10814-2

S2959

21660

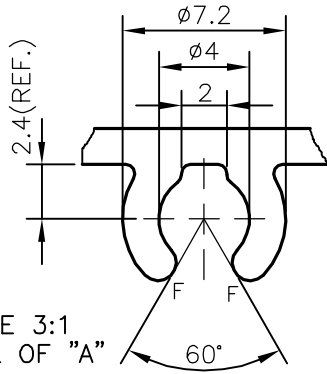

SCALE 3:1
DETAIL OF "A"

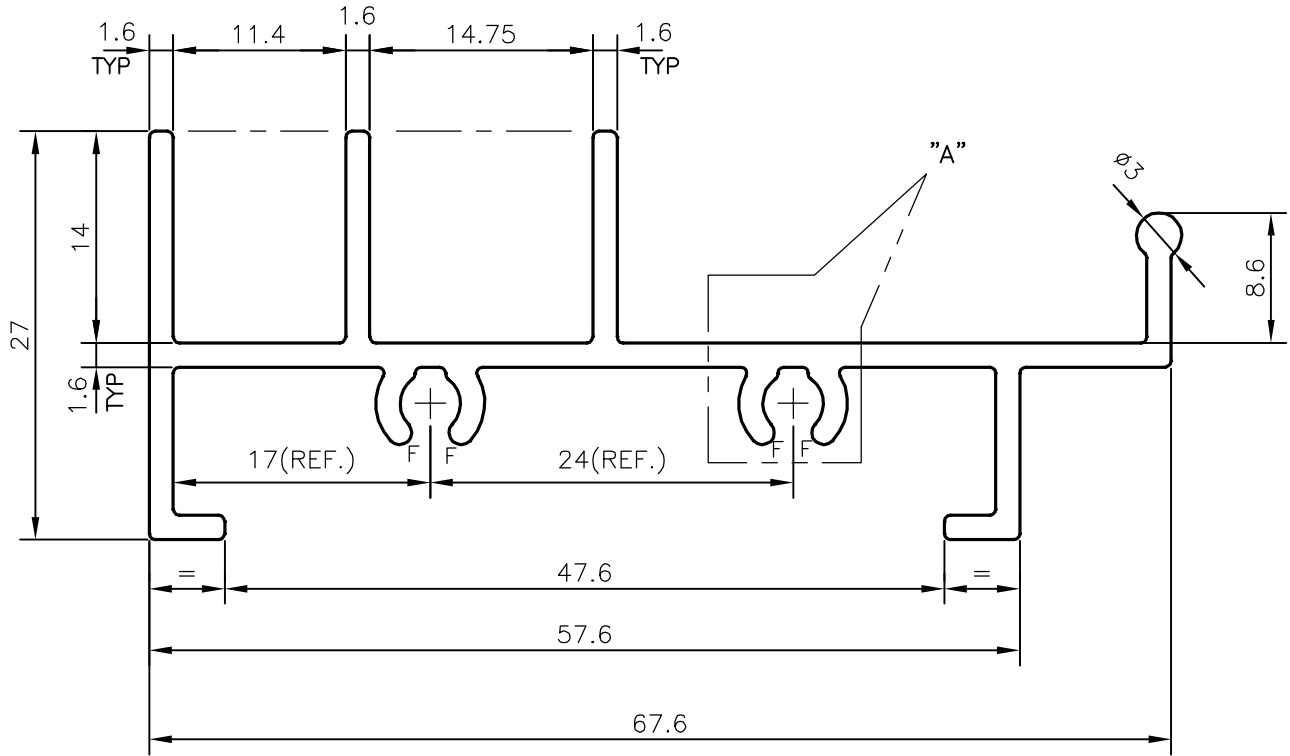
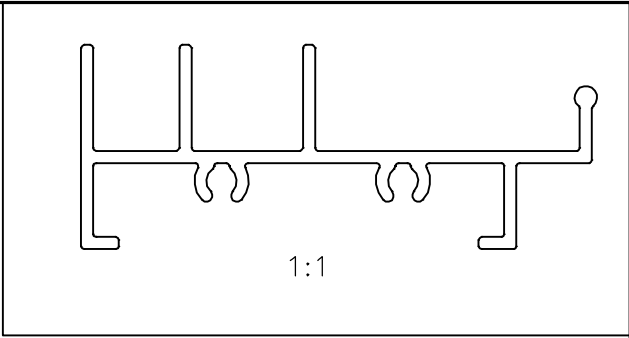

F = FULL RADIUS (4 PLACES)



SYMBOL OF QUALITY
AN ISO 9001 COMPANY

JINDAL ALUMINIUM LTD.
BANGALORE-560073 (INDIA)

	NAME	DATE
DRAWN	J.P.KAUSHIK	07-05-2011
CHECKED		
APPROVED	S.S.GARG	09-06-2011
SCALE		2:1
AREA mm ²		276.29
PERIMETER mm.		333.488
WEIGHT kg/m		0.746
DRAWING No.	SECTION No.	
P-10814-2	-	
S2959	S2959	
21660	21660	

1. ALL DIMENSIONS ARE IN mm.
2. ROUND OFF ALL SHARP CORNERS WITH 0.40 mm.
3. TOLERANCES WILL BE AS PER IS:3965-1981 UNLESS OTHERWISE SPECIFIED

PARTY'S NAME	DG-MAP, NEW DELHI
PARTY'S DRAWING No.	DGM-02
ALLOY & TEMPER	HE9 WP
DESCRIPTION	WINDOW SECTION (SL. FRAME TOP)