

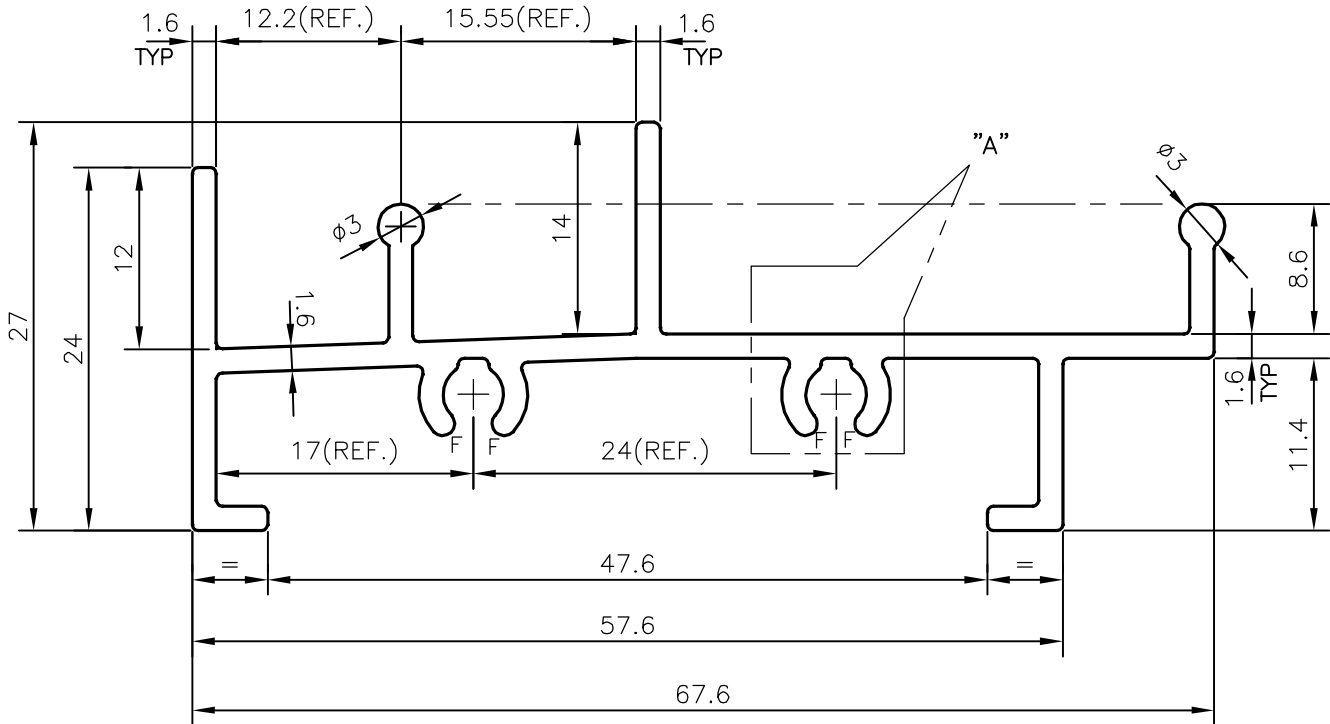

P-10815-1
S2960
21661

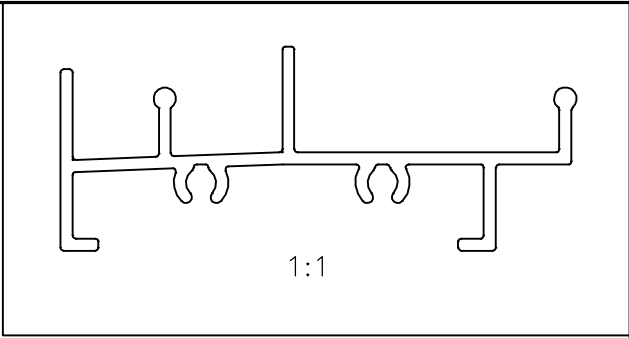
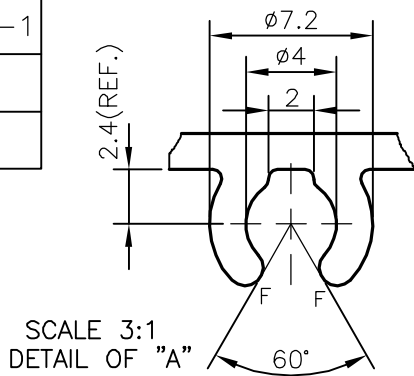

F = FULL RADIUS (4 PLACES)

 SYMBOL OF QUALITY AN ISO 9001 COMPANY	JINDAL ALUMINIUM LTD. BANGALORE-560073 (INDIA)	NAME		DATE
		DRAWN	J.P.KAUSHIK	07-05-2011
1. ALL DIMENSIONS ARE IN mm. 2. ROUND OFF ALL SHARP CORNERS WITH 0.40 mm. 3. TOLERANCES WILL BE AS PER IS:3965-1981 UNLESS OTHERWISE SPECIFIED		CHECKED		
		APPROVED	S.S.GARG	09-06-2011
PARTY'S NAME		SCALE		2:1
		AREA mm ²		266.66
PARTY'S DRAWING No.		PERIMETER mm.		317.528
		WEIGHT kg/m		0.720
ALLOY & TEMPER		DRAWING No.		SECTION No.
		P-10815-1		-
DESCRIPTION		S2960		S2960
		21661		21661