

P-13314

S3970

21678

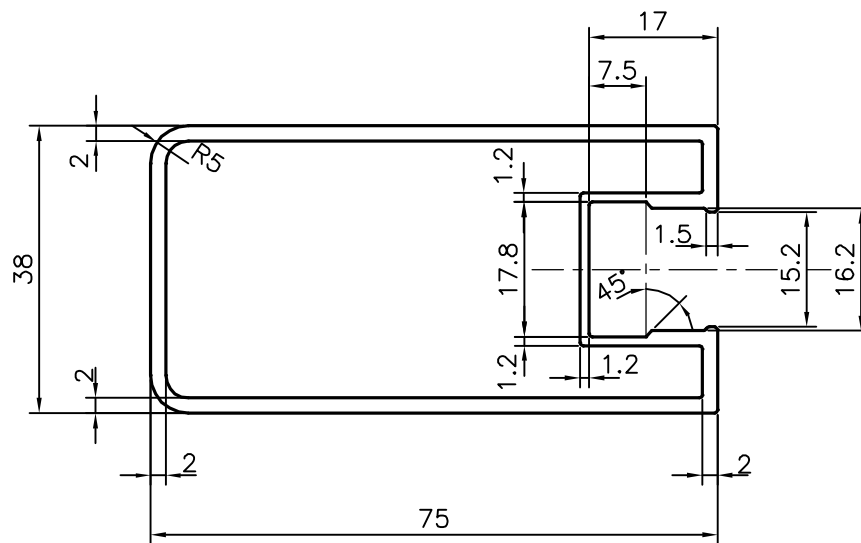

TOLERANCES ON OVERALL WIDTHS & WIDTHS ACROSS FLATS OF BARS, & REGULAR SECTIONS

UPTO 6.40mm - ± 0.20	UPTO 32.0mm - ± 0.38	UPTO 120.0mm - ± 0.85	UPTO 320.00mm - ± 1.70
UPTO 10.0mm - ± 0.23	UPTO 50.0mm - ± 0.46	UPTO 160.0mm - ± 1.02	
UPTO 12.0mm - ± 0.25	UPTO 60.0mm - ± 0.53	UPTO 200.0mm - ± 1.14	
UPTO 16.0mm - ± 0.28	UPTO 80.0mm - ± 0.69	UPTO 250.0mm - ± 1.40	
UPTO 25.0mm - ± 0.30	UPTO 100.0mm - ± 0.75	UPTO 300.0mm - ± 1.65	



SYMBOL OF QUALITY
AN ISO 9001 COMPANY

JINDAL ALUMINIUM LTD.
BANGALORE-560073 (INDIA)

	NAME	DATE
DRAWN	J.P.KAUSHIK	30-12-2013
CHECKED		
APPROVED	S.S.GARG	01-01-2014

1. ALL DIMENSIONS ARE IN mm.
2. ROUND OFF ALL SHARP CORNERS WITH 0.40 mm.
3. TOLERANCES WILL BE AS PER IS:6477-1983, UNLESS OTHERWISE SPECIFIED

SCALE	1:1
AREA mm ²	469.804
PERIMETER mm.	258.356
WEIGHT kg/m	1.268

PARTY'S NAME	ARCHANGLE ARCHITECTURAL PRODUCTS PVT. LTD., BANGALORE
PARTY'S DRAWING No.	DVP-464
ALLOY & TEMPER	HE9 WP
DESCRIPTION	MISC. SECTION

DRAWING No.	SECTION No.
P-13314	-
S3970	S3970
21678	21678