

P-13585

S4118

21699

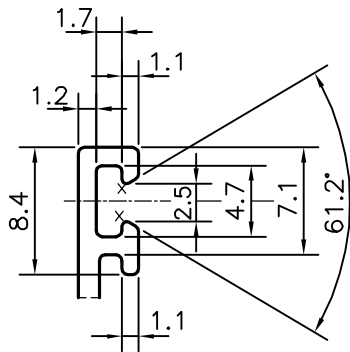
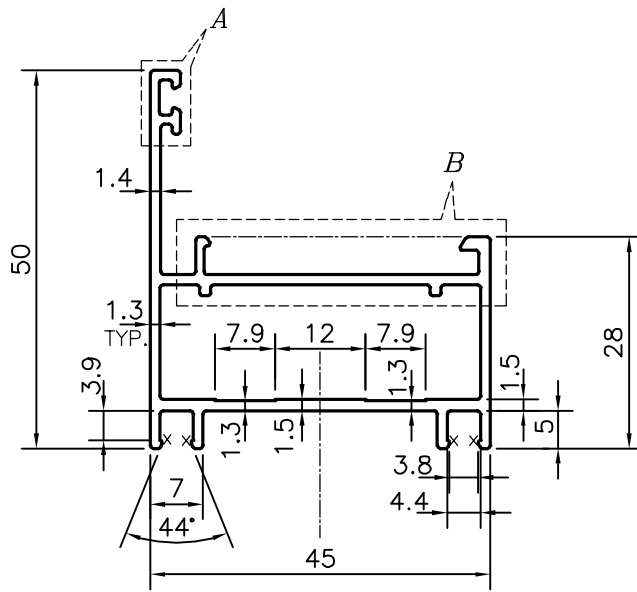

DETAIL OF "A"
SCALE 2:1

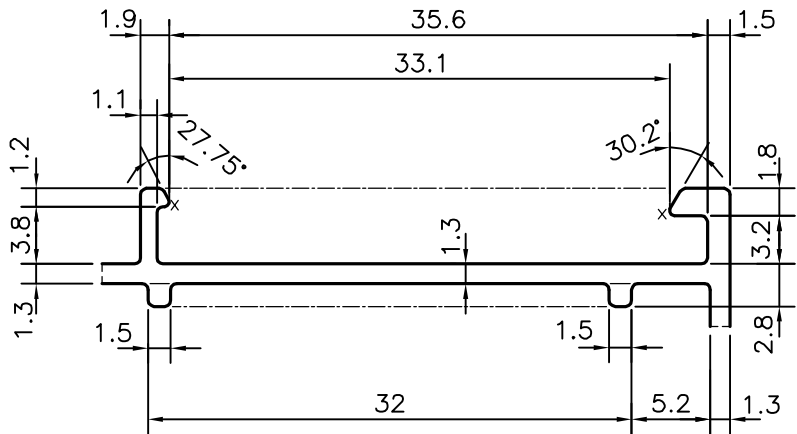

DETAIL OF "B"
SCALE 2:1

X = RADIUS 0.3 mm. (8 PLACES)



SYMBOL OF QUALITY
AN ISO 9001 COMPANY

JINDAL ALUMINIUM LTD.
BANGALORE-560073 (INDIA)

	NAME	DATE
DRAWN	J.P.KAUSHIK	13-05-2014
CHECKED		
APPROVED	S.S.GARG	24-05-2014
SCALE		1:1
AREA mm ²		258.243
PERIMETER mm.		257.996
WEIGHT kg/m		0.697
DRAWING No.	SECTION No.	
P-13585	-	
S4118	S4118	
21699	21699	

1. ALL DIMENSIONS ARE IN mm. 2. ROUND OFF ALL SHARP CORNERS WITH 0.40 mm. 3. TOLERANCES WILL BE AS PER IS:6477-1983 , UNLESS OTHERWISE SPECIFIED	
PARTY'S NAME	HATIM GLAZING & CLADDING PVT. LTD., MUMBAI
PARTY'S DRAWING No.	AS PER Auto CAD DRAWING
ALLOY & TEMPER	HE9 WP
DESCRIPTION	WINDOW SECTION