

P-13593

S4119

21700

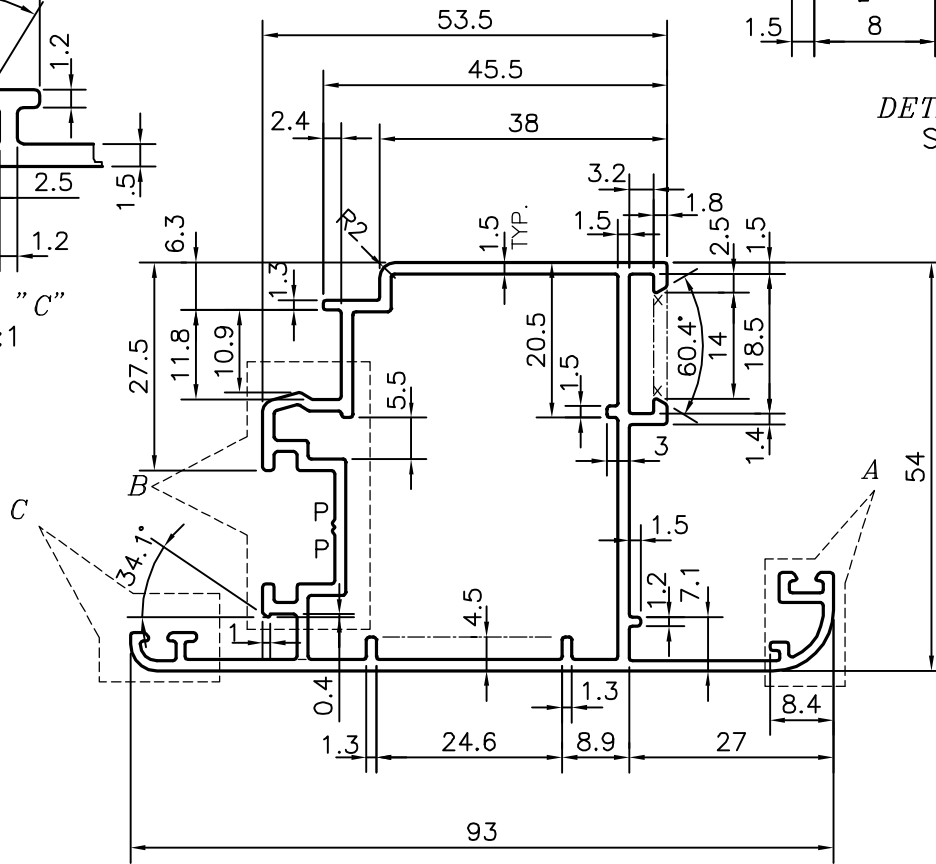
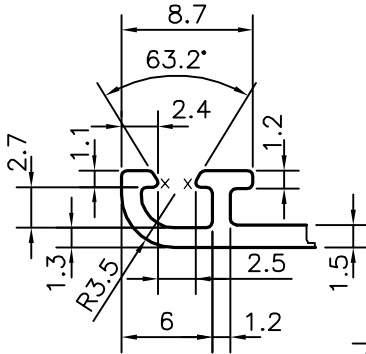
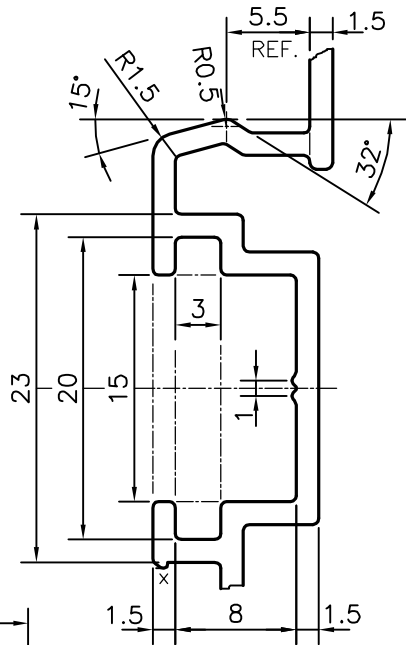
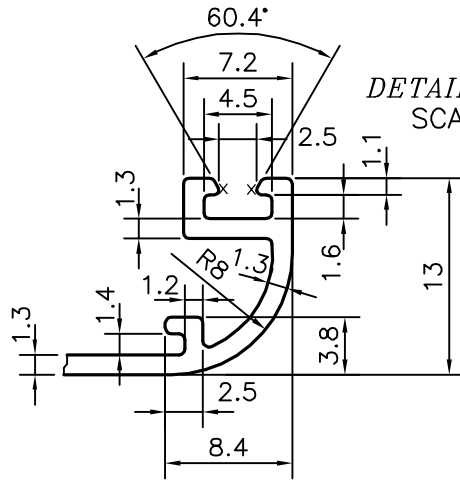

DETAIL OF "B"  
SCALE 2:1

DETAIL OF "C"  
SCALE 2:1

X = RADIUS 0.3 mm. (7 PLACES)  
P = PIP 0.3x90° (2 PLACES)



SYMBOL OF QUALITY  
AN ISO 9001 COMPANY

**JINDAL ALUMINIUM LTD.**  
BANGALORE-560073 (INDIA)

	NAME	DATE
DRAWN	J.P.KAUSHIK	17-05-2014
CHECKED		
APPROVED	S.S.GARG	24-05-2014
SCALE		1:1
AREA mm <sup>2</sup>		472.746
PERIMETER mm.		420.815
WEIGHT kg/m		1.276
DRAWING No.	SECTION No.	
P-13593	-	
S4119	S4119	
21700	21700	

1. ALL DIMENSIONS ARE IN mm.
2. ROUND OFF ALL SHARP CORNERS WITH 0.40 mm.
3. TOLERANCES WILL BE AS PER IS:6477-1983 , UNLESS OTHERWISE SPECIFIED

PARTY'S NAME	HATIM GLAZING & CLADDING PVT. LTD., MUMBAI
PARTY'S DRAWING No.	AS PER AutoCAD DRAWING
ALLOY & TEMPER	HE9 WP
DESCRIPTION	WINDOW SECTION