

P-13594

S4120

21701

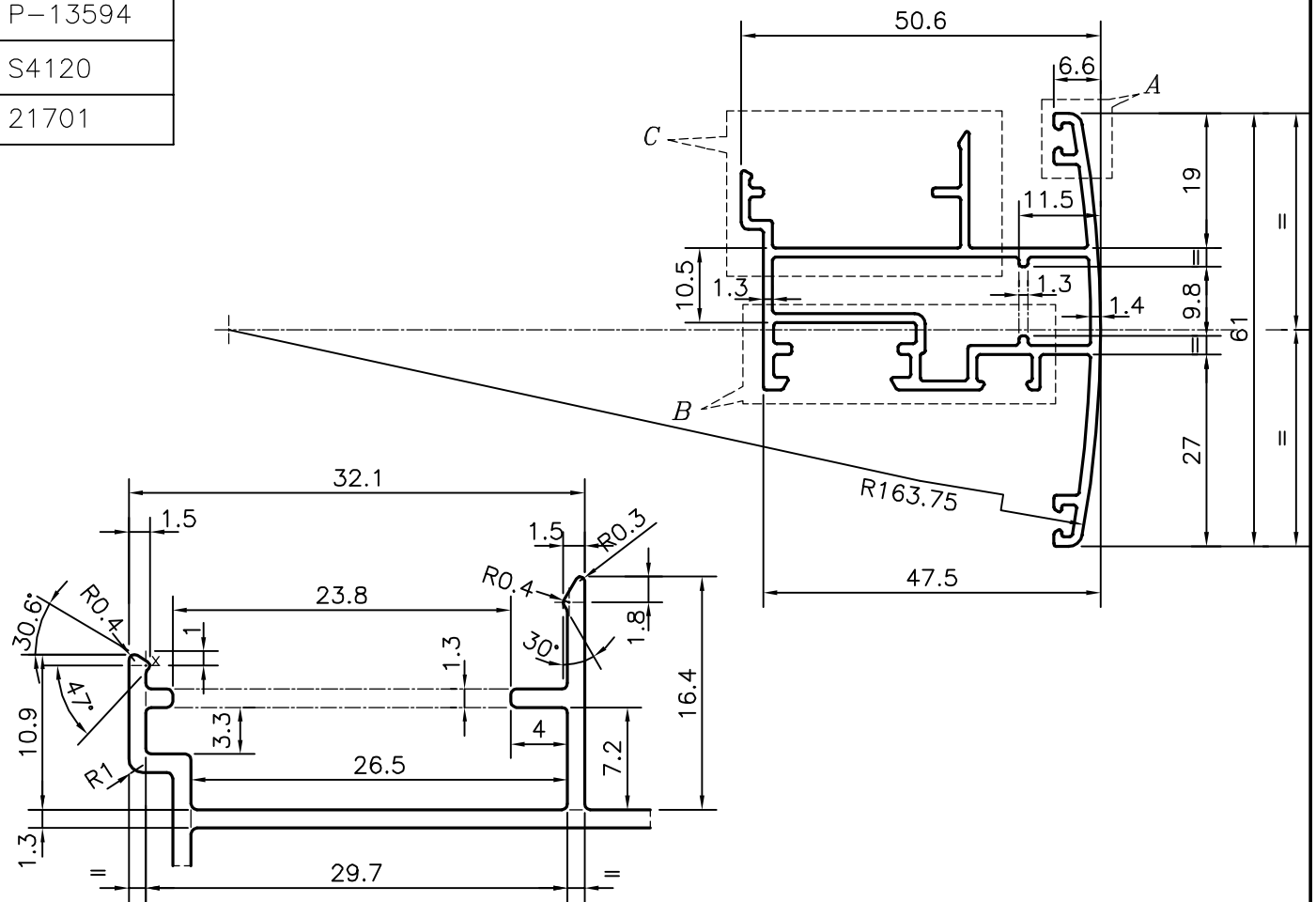

DETAIL OF "C"
SCALE 2:1

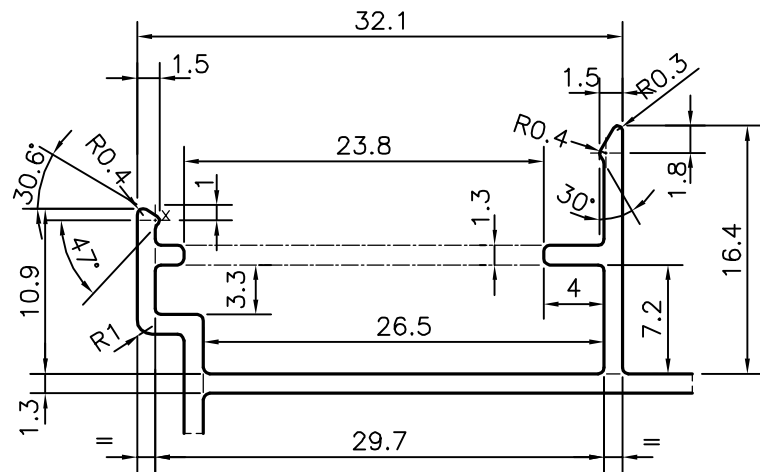

DETAIL OF "B"
SCALE 2:1

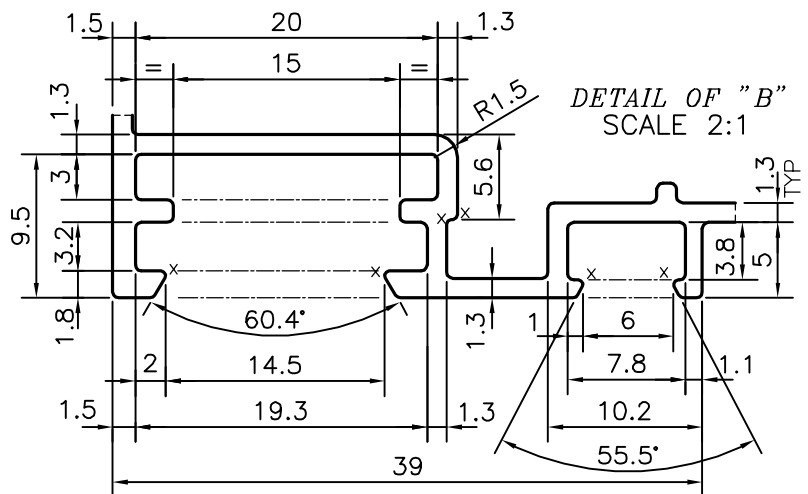

DETAIL OF "A"
SCALE 2:1

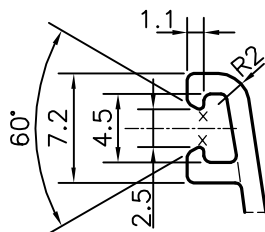

X = RADIUS 0.3 mm. (9 PLACES)



SYMBOL OF QUALITY
AN ISO 9001 COMPANY

JINDAL ALUMINIUM LTD.
BANGALORE-560073 (INDIA)

	NAME	DATE
DRAWN	J.P.KAUSHIK	17-05-2014
CHECKED		
APPROVED	S.S.GARG	24-05-2014
SCALE		1:1
AREA mm ²		338.023
PERIMETER mm.		368.279
WEIGHT kg/m		0.913
DRAWING No.	SECTION No.	
P-13594	-	
S4120	S4120	
21701	21701	

1. ALL DIMENSIONS ARE IN mm.	
2. ROUND OFF ALL SHARP CORNERS WITH 0.40 mm.	
3. TOLERANCES WILL BE AS PER IS:6477-1983 , UNLESS OTHERWISE SPECIFIED	
PARTY'S NAME	HATIM GLAZING & CLADDING PVT. LTD., MUMBAI
PARTY'S DRAWING No.	AS PER AutoCAD DRAWING
ALLOY & TEMPER	HE9 WP
DESCRIPTION	WINDOW SECTION