

P-16082

21710

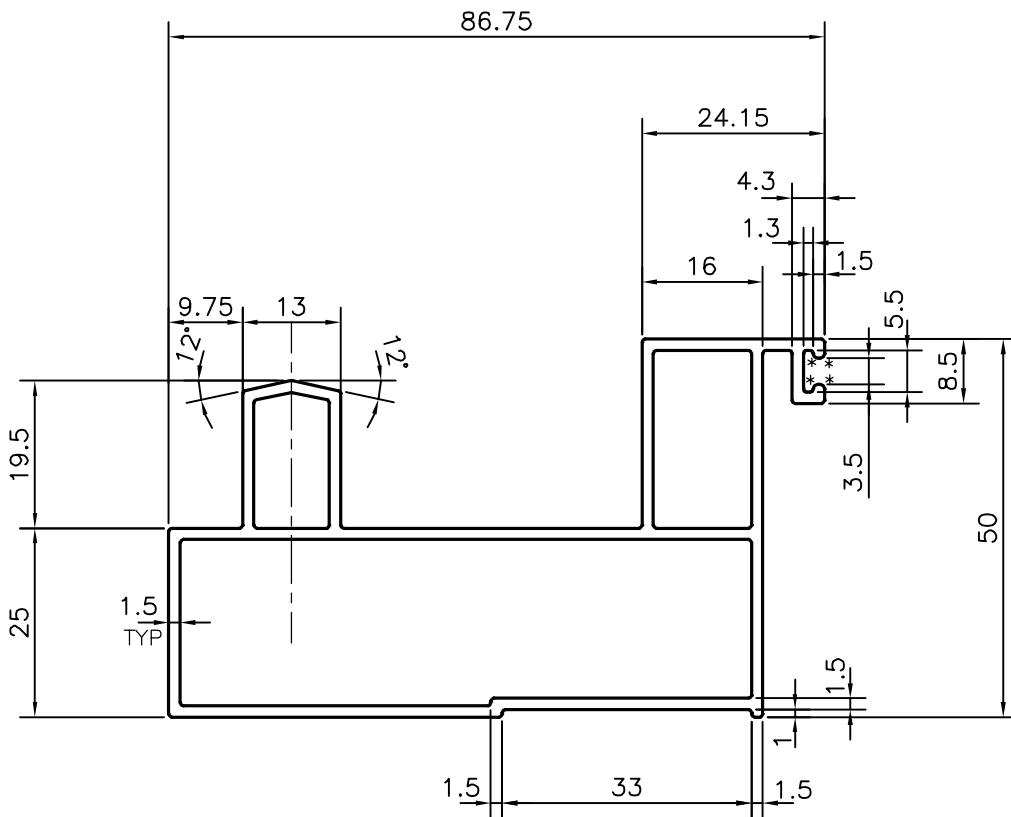

* = 0.60 RADIUS (4 PLACES)

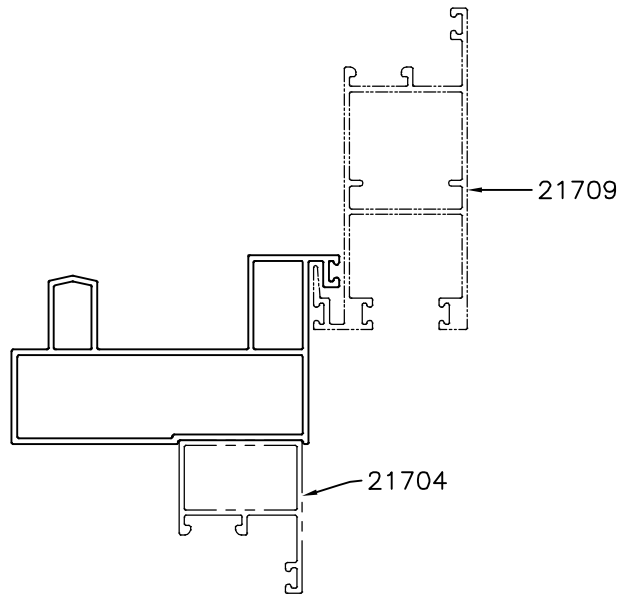

SYMBOL OF QUALITY
AN ISO 9001 COMPANY

JINDAL ALUMINIUM LTD.
BANGALORE-560073 (INDIA)

	NAME	DATE
DRAWN	J.P.KAUSHIK	21-07-2016
CHECKED		
APPROVED	S.S. GARG	23-07-2016
SCALE		1:1
AREA mm ²		498.023
PERIMETER mm.		330.972
WEIGHT kg/m		1.345
DRAWING No.	SECTION No.	
P-16082	-	
21710	21710	

1. ALL DIMENSIONS ARE IN mm.
2. ROUND OFF ALL SHARP CORNERS WITH 0.40 mm.
3. TOLERANCES WILL BE AS PER IS:6477-1983, UNLESS OTHERWISE SPECIFIED

PARTY'S NAME	GENERAL CATEGORY, DELHI MARKET
PARTY'S DRAWING No.	AS PER DRAWING
ALLOY & TEMPER	HE9 WP
DESCRIPTION	WINDOW SECTION