

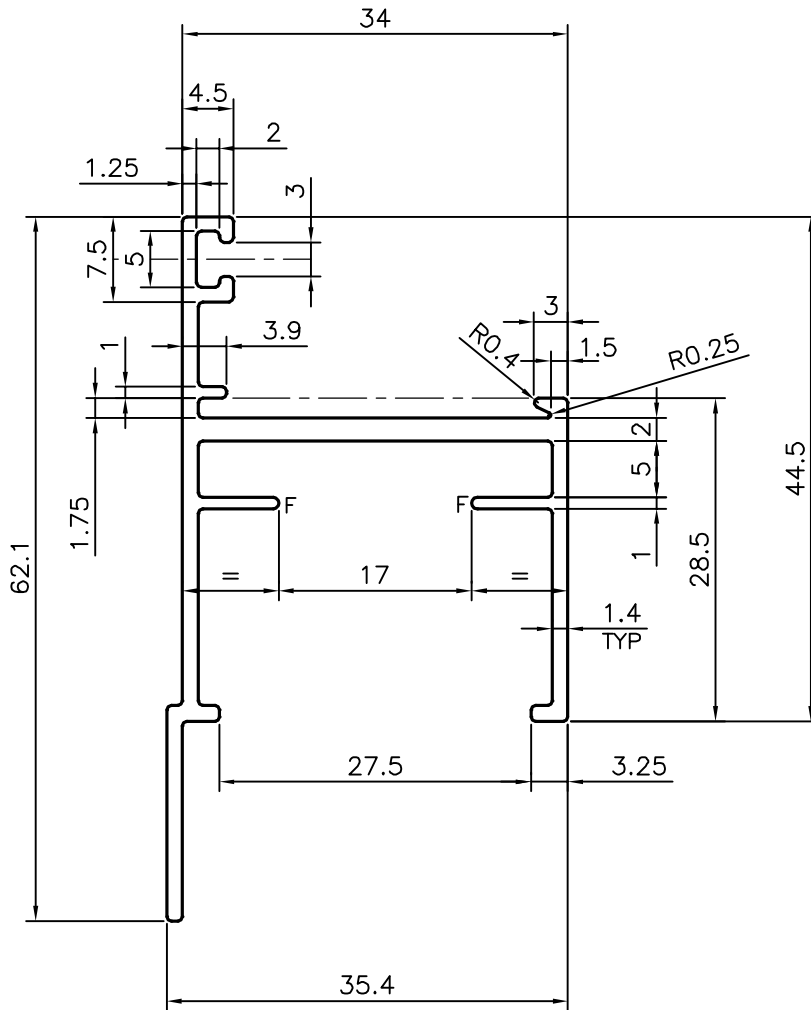

P-15802
S4945
21715

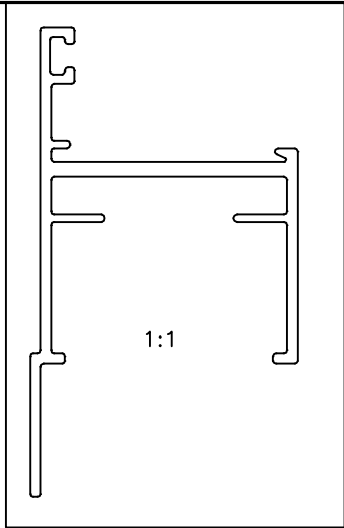

F = FULL RADIUS (2 PLACES)

 SYMBOL OF QUALITY AN ISO 9001 COMPANY	JINDAL ALUMINIUM LTD. BANGALORE-560073 (INDIA)	DRAWN	J.P.KAUSHIK	DATE	25-04-2016
		CHECKED			
1. ALL DIMENSIONS ARE IN mm. 2. ROUND OFF ALL SHARP CORNERS WITH 0.40 mm. 3. TOLERANCES WILL BE AS PER IS:3965-1981 UNLESS OTHERWISE SPECIFIED		APPROVED	S.S. GARG	20-05-2016	
		SCALE		1.5:1	
PARTY'S NAME MANTRALAYA IMPEX, CHENNAI		AREA mm ²		224.01	
		PERIMETER mm.		300.555	
PARTY'S DRAWING No. AS PER DRAWING		WEIGHT kg/m		0.605	
		DRAWING No.	P-15802	SECTION No.	-
ALLOY & TEMPER HE9 WP			S4945		S4945
			21715		21715
DESCRIPTION WINDOW SECTION					