

P-15635-1

21716

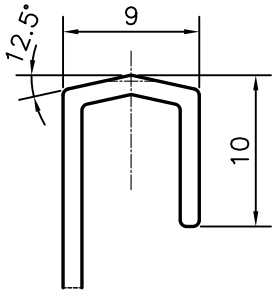

DETAIL OF "A"  
SCALE 2:1

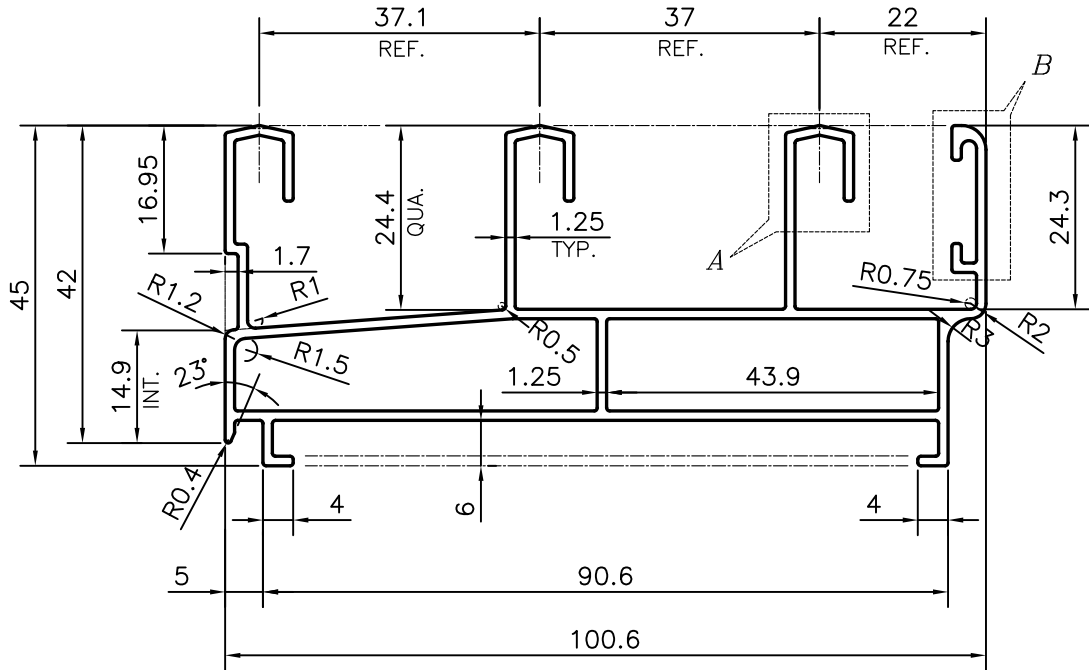
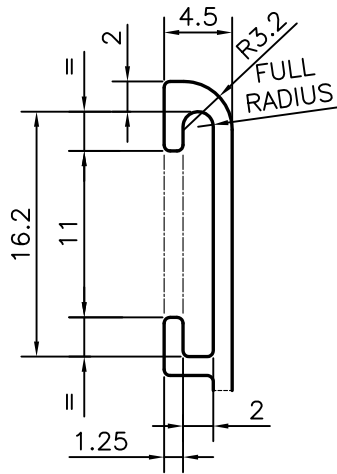

DETAIL OF "B"  
SCALE 2:1



SYMBOL OF QUALITY  
AN ISO 9001 COMPANY

**JINDAL ALUMINIUM LTD.**  
BANGALORE-560073 (INDIA)

	NAME	DATE
DRAWN	PARVESH	01-03-2016
CHECKED		
APPROVED	S.S. GARG	26-07-2016
SCALE		1:1
AREA mm <sup>2</sup>		512.889
PERIMETER mm.		571.44
WEIGHT kg/m		1.385
DRAWING No.	SECTION No.	
P-15635-1	-	
21716	21716	

1. ALL DIMENSIONS ARE IN mm.
2. ROUND OFF ALL SHARP CORNERS WITH 0.40 mm.
3. TOLERANCES WILL BE AS PER IS:6477-1983, UNLESS OTHERWISE SPECIFIED

PARTY'S NAME	GENERAL CATEGORY, MUMBAI MARKET
PARTY'S DRAWING No.	LIGHTER OF SECTION No. 21242
ALLOY & TEMPER	HE9 WP
DESCRIPTION	WINDOW SECTION-DELUX