

P-16335-1

21723

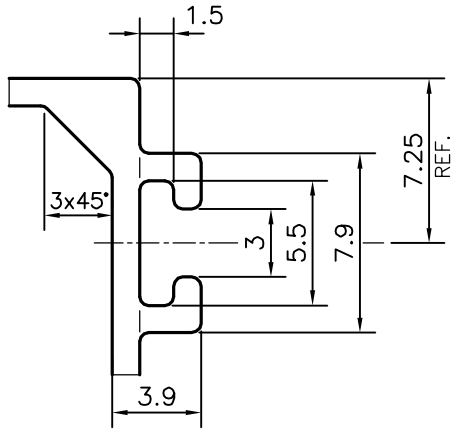

DETAIL OF "A"
SCALE:- 3:1

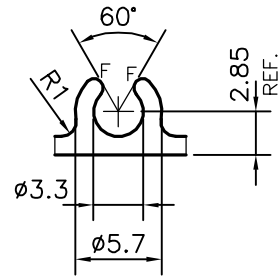

DETAIL OF "B"
SCALE:- 2:1

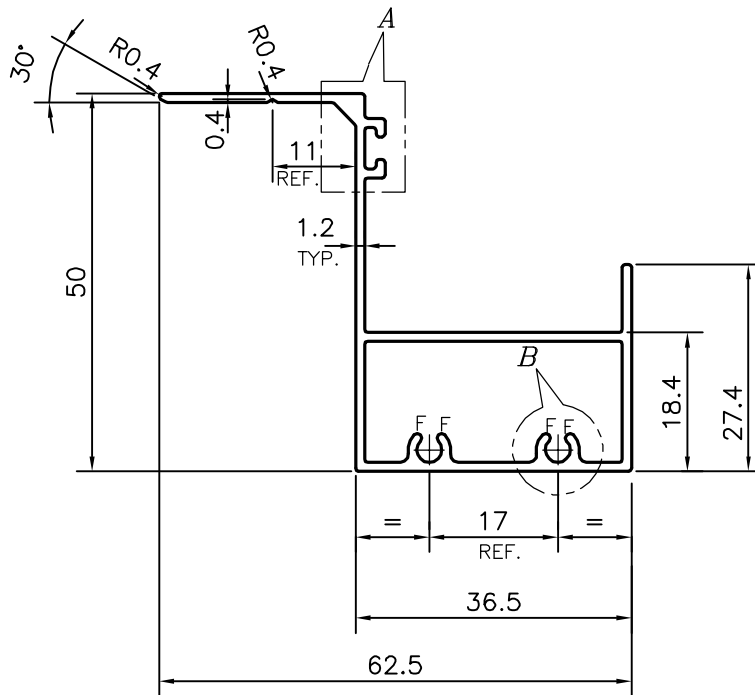

F = FULL RADIUS (4 PLACES)



SYMBOL OF QUALITY
AN ISO 9001 COMPANY

JINDAL ALUMINIUM LTD.
BANGALORE-560073 (INDIA)

	NAME	DATE
DRAWN	J.P.KAUSHIK	22-09-2016
CHECKED		
APPROVED	S.S. GARG	27-09-2016
SCALE		1:1
AREA mm ²		240.815
PERIMETER mm.		253.373
WEIGHT kg/m		0.650
DRAWING No.	SECTION No.	
P-16335-1	-	
21723	21723	

1. ALL DIMENSIONS ARE IN mm.
2. ROUND OFF ALL SHARP CORNERS WITH 0.40 mm.
3. TOLERANCES WILL BE AS PER BS:EN-755-9, UNLESS OTHERWISE SPECIFIED

PARTY'S NAME	PRAYOSHA ENTERPRISES LTD., UGANDA
PARTY'S DRAWING No.	MODIFIED OF SECTION No.-21307
ALLOY & TEMPER	6063 T6
DESCRIPTION	WINDOW SECTION