

P-13970

S4232

21725

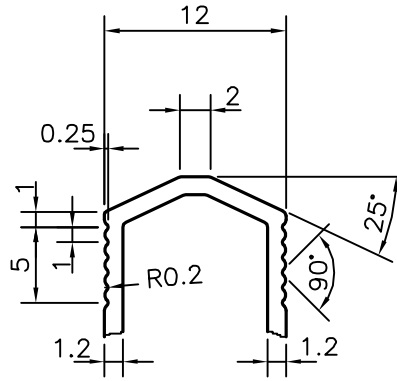

DETAIL OF "A"  
SCALE 2:1

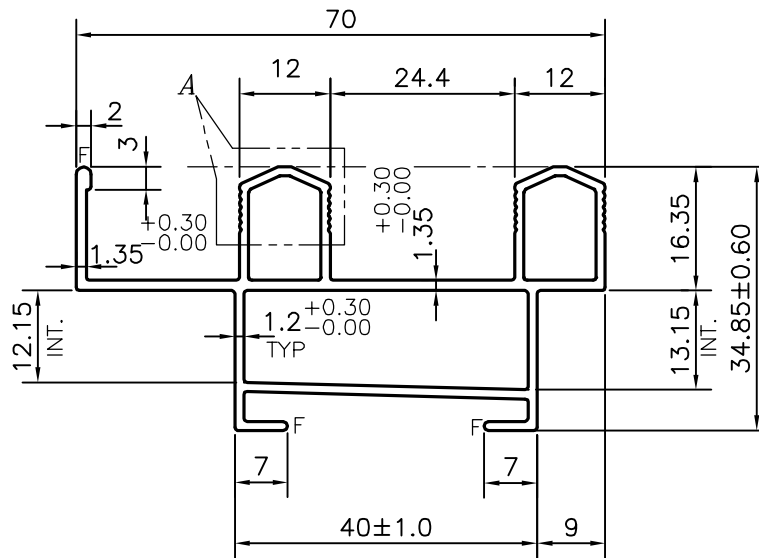

F = FULL RADIUS(3 PLACES)



SYMBOL OF QUALITY  
AN ISO 9001 COMPANY

**JINDAL ALUMINIUM LTD.**  
BANGALORE-560073 (INDIA)

	NAME	DATE
DRAWN	J.P.KAUSHIK	06-09-2014
CHECKED		
APPROVED	S.S.GARG	11-09-2014
SCALE		1:1
AREA mm <sup>2</sup>		304.395
PERIMETER mm.		295.194
WEIGHT kg/m		0.822
DRAWING No.	SECTION No.	
P-13970	-	
S4232	S4232	
21725	21725	

1. ALL DIMENSIONS ARE IN mm.
2. ROUND OFF ALL SHARP CORNERS WITH 0.40 mm.
3. TOLERANCES WILL BE AS PER IS:6477-1983 , UNLESS OTHERWISE SPECIFIED

PARTY'S NAME	PARAMOUNT INDUSTRIES, BANGALORE
PARTY'S DRAWING No.	P-AL172414LWA
ALLOY & TEMPER	HE9 WP
DESCRIPTION	WINDOW SECTION