

P-13967

S4244

21729

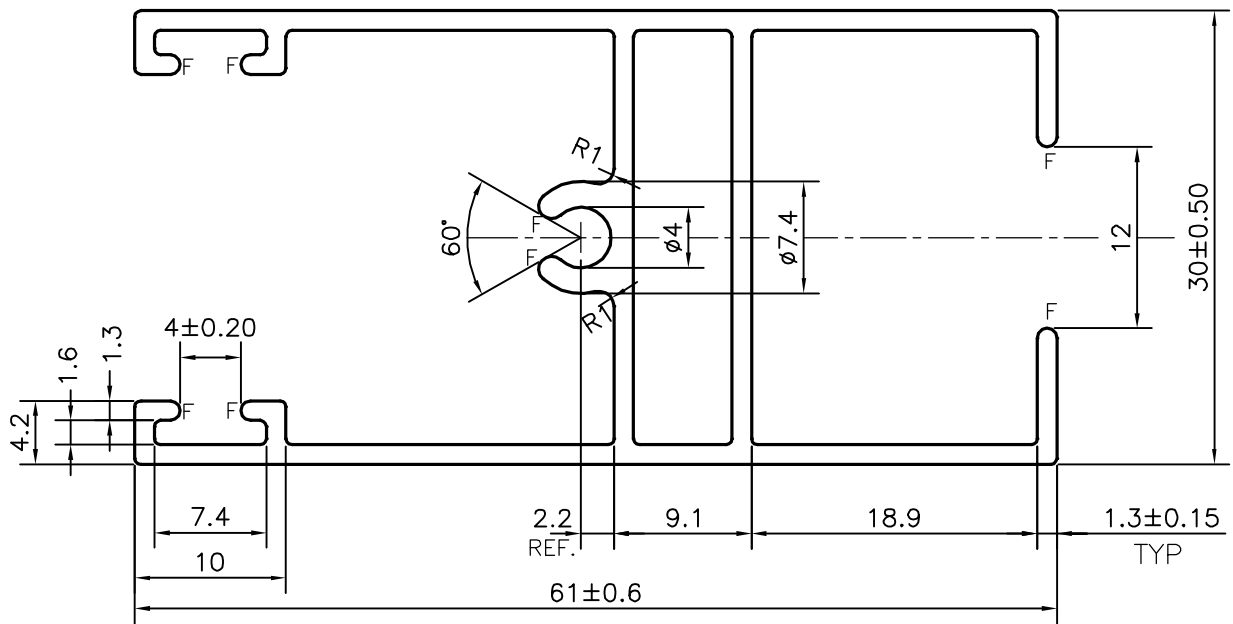
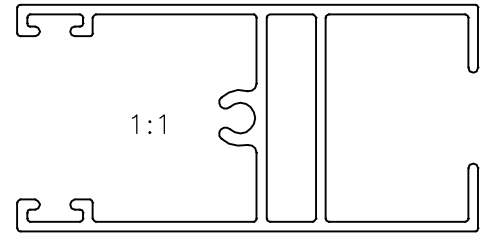

F = FULL RADIUS(8 PLACES)



SYMBOL OF QUALITY
AN ISO 9001 COMPANY

JINDAL ALUMINIUM LTD.
BANGALORE-560073 (INDIA)

	NAME	DATE
DRAWN	J.P.KAUSHIK	05-09-2014
CHECKED		
APPROVED	S.S.GARG	13-09-2014
SCALE		2:1
AREA mm ²		292.55
PERIMETER mm.		362.521
WEIGHT kg/m		0.790
DRAWING No.	SECTION No.	
P-13967	-	
S4244	S4244	
21729	21729	

1. ALL DIMENSIONS ARE IN mm.
2. ROUND OFF ALL SHARP CORNERS WITH 0.40 mm.
3. TOLERANCES WILL BE AS PER IS:6477-1983 , UNLESS OTHERWISE SPECIFIED

PARTY'S NAME	PARAMOUNT INDUSTRIES, BANGALORE
PARTY'S DRAWING No.	P-AL8761H2
ALLOY & TEMPER	HE9 WP
DESCRIPTION	WINDOW SECTION