

P-16378

S5087

21734

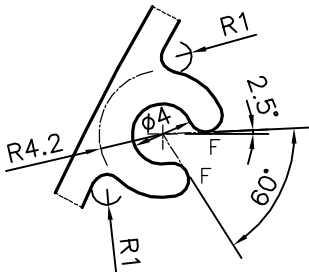
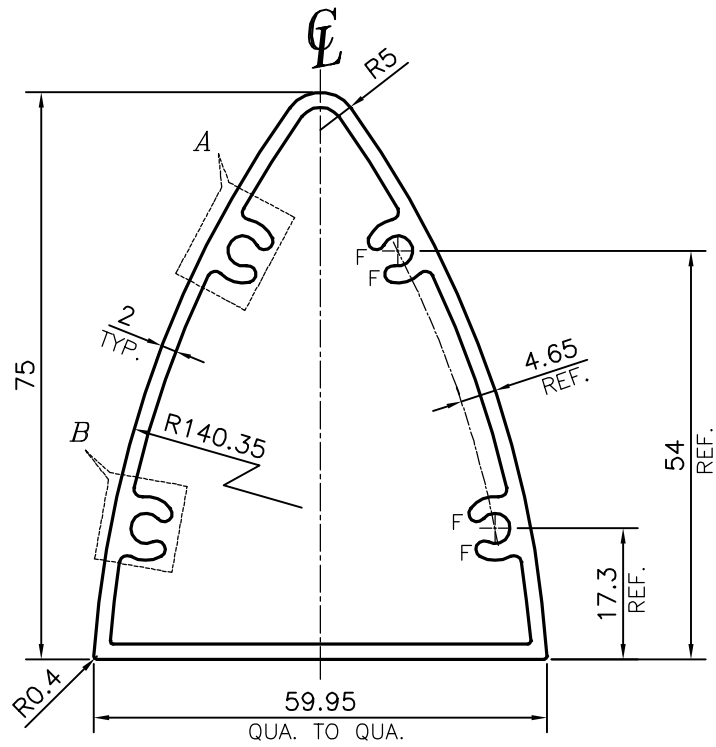

DETAIL OF "A"
SCALE 2:1

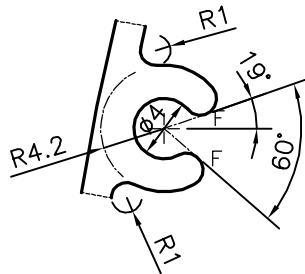

DETAIL OF "B"
SCALE 2:1

F = FULL RADIUS (8 PLACES)

 SYMBOL OF QUALITY AN ISO 9001 COMPANY	JINDAL ALUMINIUM LTD. BANGALORE-560073 (INDIA)	NAME	DATE
		DRAWN	PARVESH 20-09-2016
		CHECKED	
		APPROVED	S.S. GARG 24-09-2016
		SCALE	1:1
		AREA mm ²	552.474
		PERIMETER mm.	225.903
		WEIGHT kg/m	1.492
PARTY'S NAME	MARVEL TOUCH ALUMINIUM PVT. LTD., MUMBAI	DRAWING No.	SECTION No.
PARTY'S DRAWING No.	AS PER AUTOCAD DRAWING-FIN(A)	P-16378	-
ALLOY & TEMPER	6063 T6	S5087	S5087
DESCRIPTION	LOUVER SECTION	21734	21734