

P-15768

S4932

21739

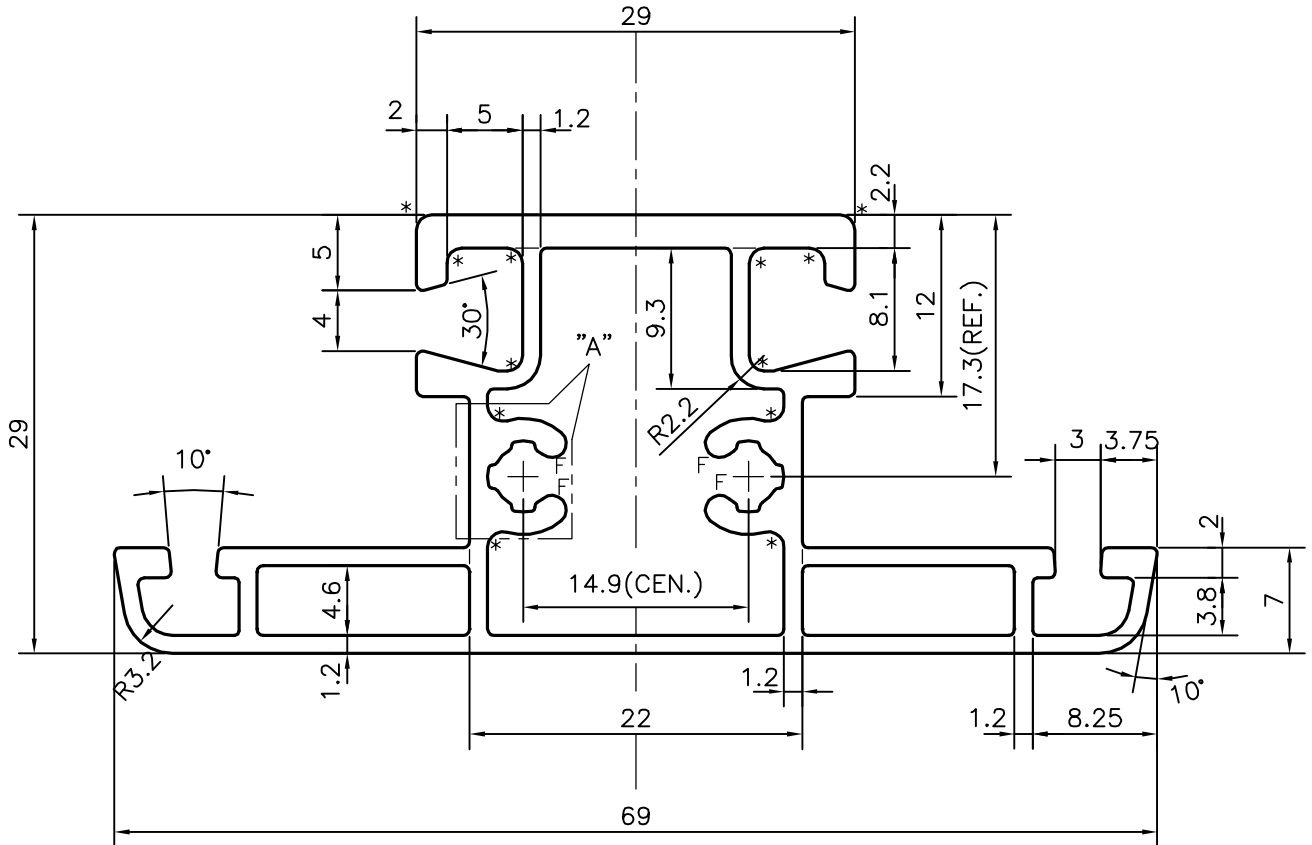
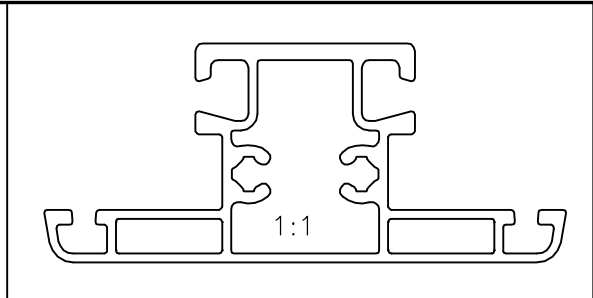
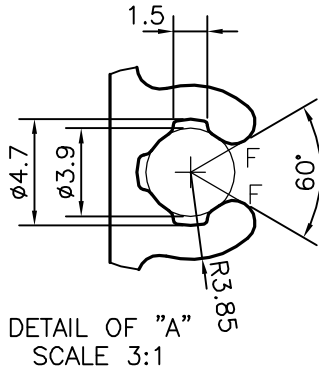

F = FULL RADIUS (4 PLACES)

* = 1.0 RADIUS (12 PLACES)



SYMBOL OF QUALITY
AN ISO 9001 COMPANY

JINDAL ALUMINIUM LTD.
BANGALORE-560073 (INDIA)

	NAME	DATE
DRAWN	J.P.KAUSHIK	12-04-2016
CHECKED		
APPROVED	B. NATARAJ	06-05-2016
SCALE		2:1
AREA mm ²		359.718
PERIMETER mm.		274.898
WEIGHT kg/m		0.971
DRAWING No.	SECTION No.	
P-15768	-	
S4932	S4932	
21739	21739	

1. ALL DIMENSIONS ARE IN mm.
2. ROUND OFF ALL SHARP CORNERS WITH 0.40 mm.
3. TOLERANCES WILL BE AS PER,IS:6477-1983 UNLESS OTHERWISE SPECIFIED

PARTY'S NAME	MANTRALAYA IMPEX, CHENNAI
PARTY'S DRAWING No.	AS PER AutoCAD DRAWING
ALLOY & TEMPER	HE9 WP
DESCRIPTION	MULLION SECTION