

P-14111

S4314

21740

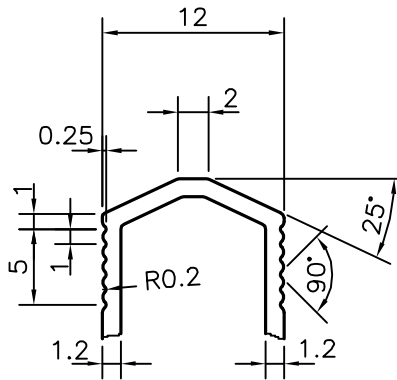

DETAIL OF "A"
SCALE 2:1

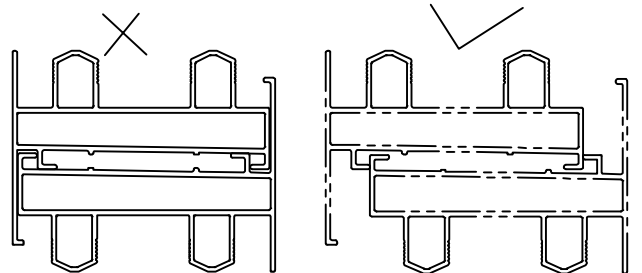
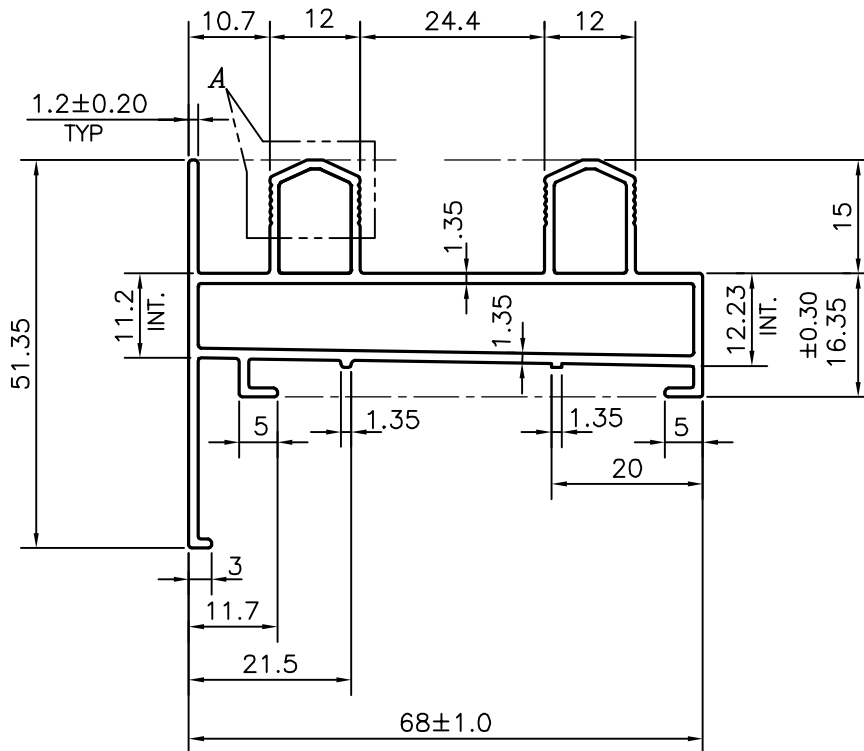

SYMBOL OF QUALITY
AN ISO 9001 COMPANY

JINDAL ALUMINIUM LTD.
BANGALORE-560073 (INDIA)

	NAME	DATE
DRAWN	J.P.KAUSHIK	19-11-2014
CHECKED		
APPROVED	S.S.GARG	05-12-2014
SCALE		1:1
AREA mm ²		362.427
PERIMETER mm.		331.117
WEIGHT kg/m		0.979
DRAWING No.	SECTION No.	
P-14111	-	
S4314	S4314	
21740	21740	

1. ALL DIMENSIONS ARE IN mm.
2. ROUND OFF ALL SHARP CORNERS WITH 0.40 mm.
3. TOLERANCES WILL BE AS PER IS:6477-1983 , UNLESS OTHERWISE SPECIFIED

PARTY'S NAME	PARAMOUNT INDUSTRIES, BANGALORE
PARTY'S DRAWING No.	P-AL172417L & AS PER AutoCAD DRAWING
ALLOY & TEMPER	HE9 WP
DESCRIPTION	WINDOW SECTION