

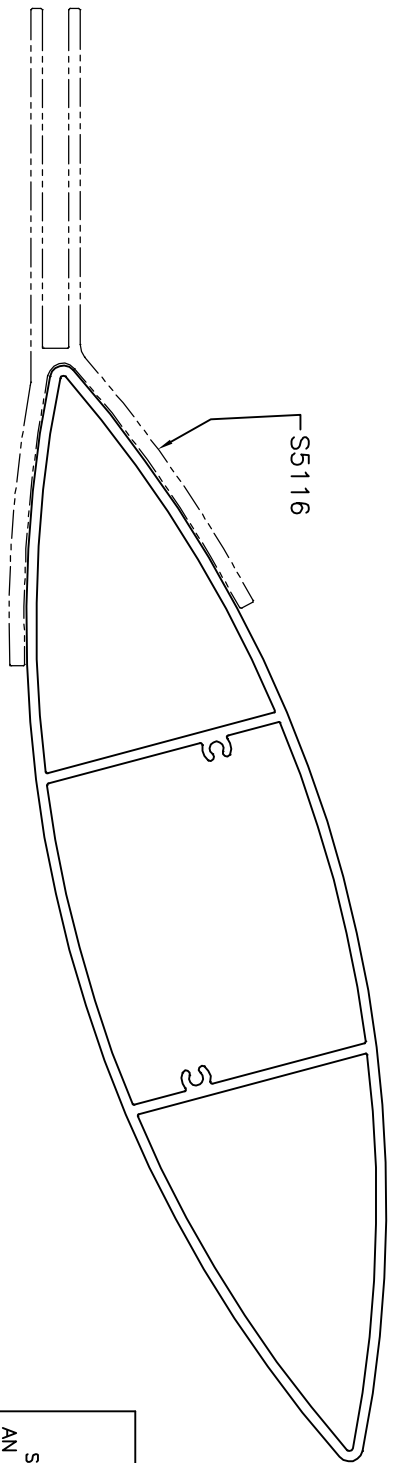

P-16370
SS117
21753

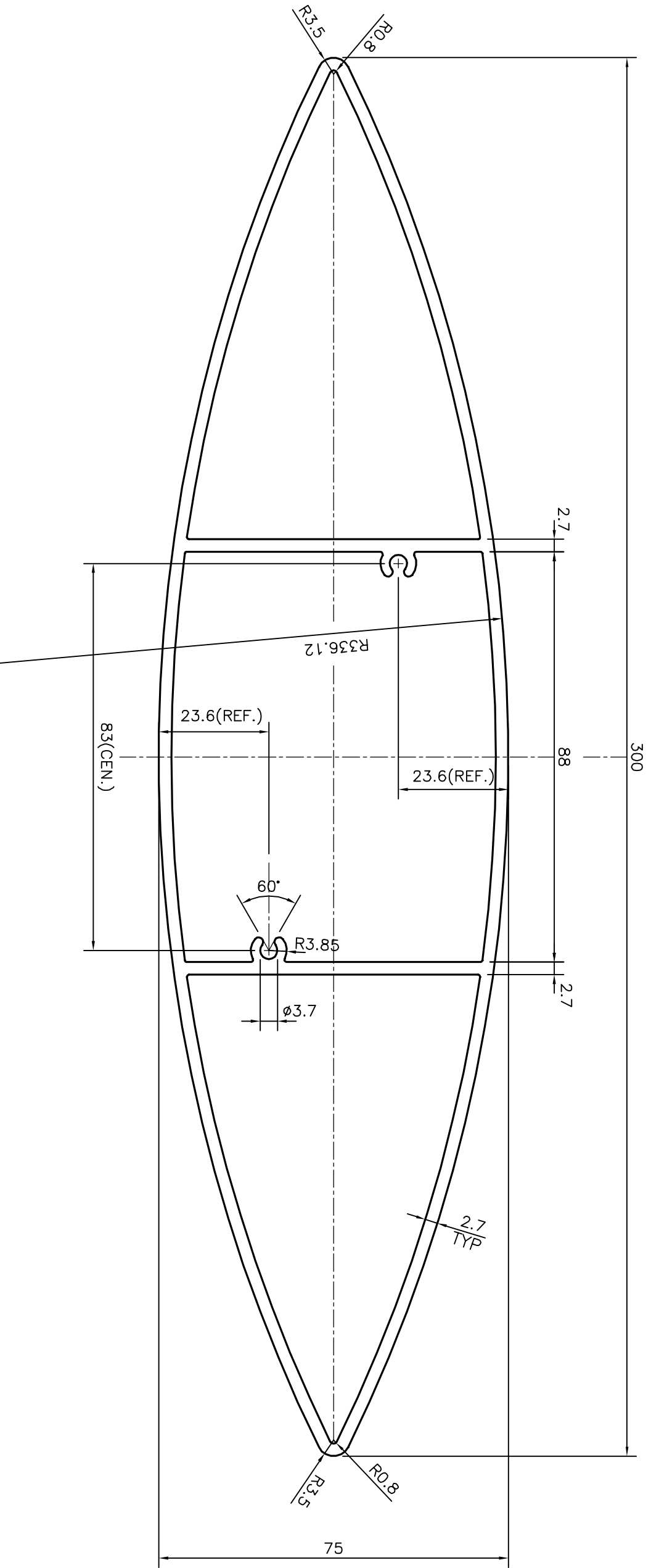

 SYMBOL OF QUALITY AN ISO 9001 COMPANY		JINDAL ALUMINIUM LTD. BANGALORE-560073 (INDIA)	
1. ALL DIMENSIONS ARE IN mm. 2. ROUND OFF ALL SHARP CORNERS WITH 0.40 mm. 3. TOLERANCES WILL BE AS PER IS:6477-1983 UNLESS OTHERWISE SPECIFIED		DRAWN J.P. KAUSHIK 21-09-2016	NAME J.P. KAUSHIK DATE 21-09-2016
PARTY'S NAME MARVEL TOUCH ALUMINIUM PVT. LTD., MUMBAI	PARTY'S DRAWING No. AS PER AutocAD DRAWING	CHECKED B. NATARAU	APPROVED B. NATARAU 19-10-2016
ALLOY & TEMPER 6063 T6	SCALE 1:1	AREA mm ² 2065.094	PERIMETER mm. 628.812
DESCRIPTION LOUVER SECTION	WEIGHT kg/m 5.576	DRAWING No. P-16370	SECTION No. -