

P-14862

S4557

21758

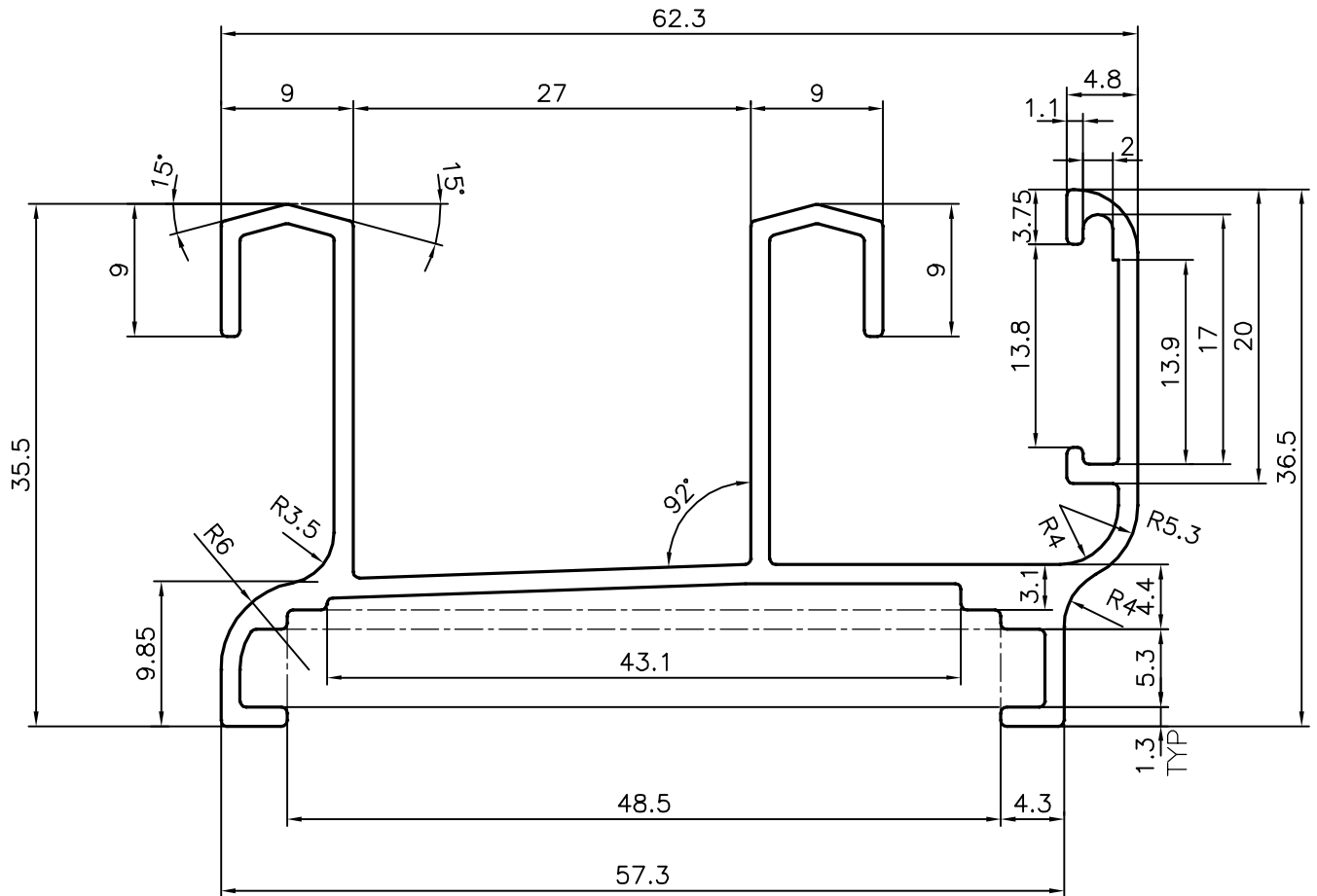
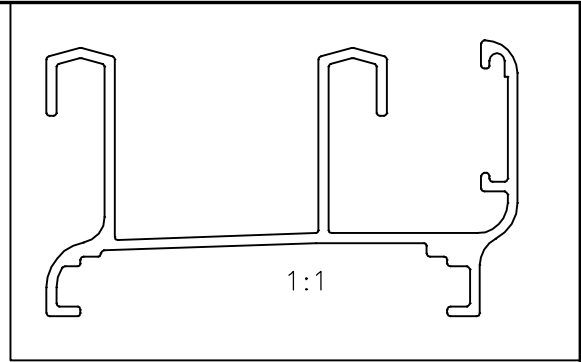

SYMBOL OF QUALITY
AN ISO 9001 COMPANY

JINDAL ALUMINIUM LTD.
BANGALORE-560073 (INDIA)

	NAME	DATE
DRAWN	J.P.KAUSHIK	10-07-2015
CHECKED		
APPROVED	S.S.GARG	30-07-2015
SCALE		2:1
AREA mm ²		273.783
PERIMETER mm.		383.545
WEIGHT kg/m		0.739
DRAWING No.	SECTION No.	
P-14862	-	
S4557	S4557	
21758	21758	

1. ALL DIMENSIONS ARE IN mm.
2. ROUND OFF ALL SHARP CORNERS WITH 0.40 mm.
3. TOLERANCES WILL BE AS PER IS:3965-1981, UNLESS OTHERWISE SPECIFIED

PARTY'S NAME	FULL SPACE INTERIORS, MUMBAI
PARTY'S DRAWING No.	AS PER SAMPLE
ALLOY & TEMPER	HE9 WP
DESCRIPTION	WINDOW SECTION