

P-15076

S4606

21784

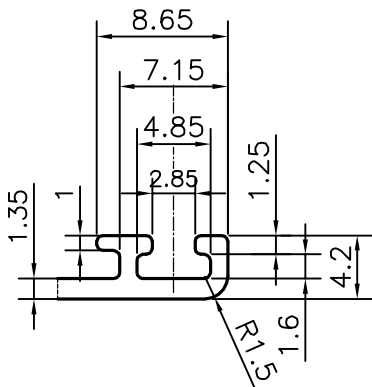

DETAIL OF "A"  
SCALE 2:1

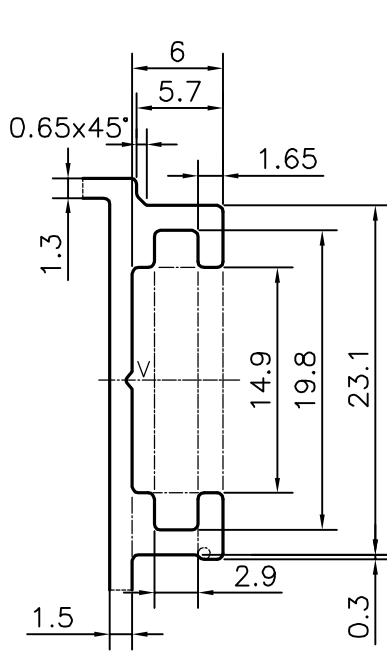
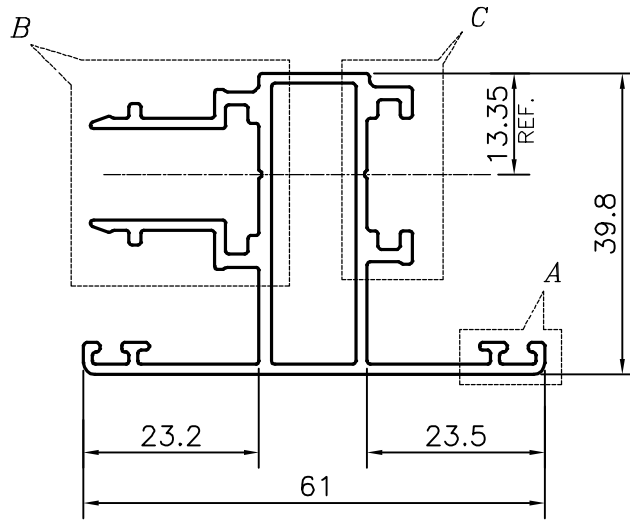

DETAIL OF "B"  
SCALE 2:1

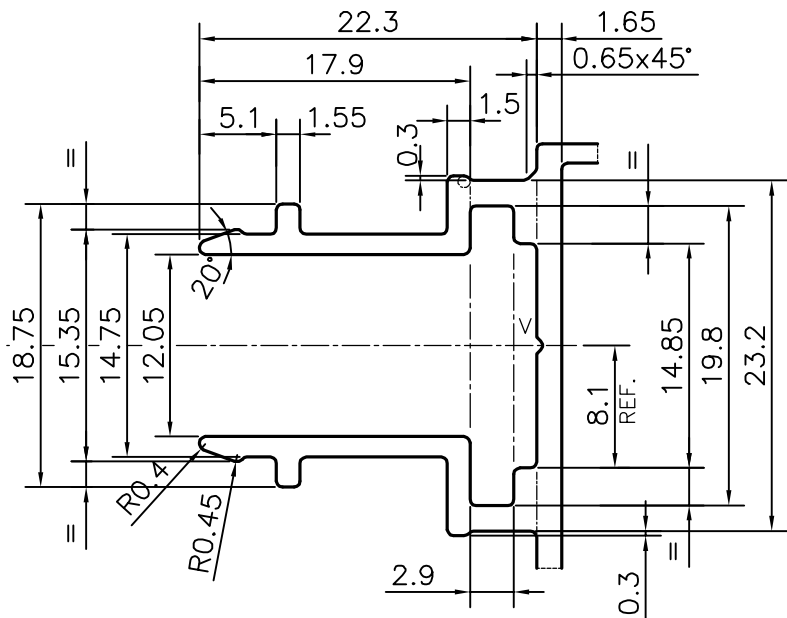

DETAIL OF "C"  
SCALE 2:1

V = VEE GROOVE 0.4x90° (2 PLACES)

TOLERANCES ON OVERALL WIDTHS & WIDTHS ACROSS FLATS OF BARS, & REGULAR SECTIONS

UPTO 6.40mm - ±0.20	UPTO 32.0mm - ±0.38	UPTO 120.0mm - ±0.85	1. STRAIGHTNESS=1.7mm/M 2. TWIST=1.7mm/M 3. ANGULARITY= ±2° 4. FLATNESS =0.007xWIDTH
UPTO 10.0mm - ±0.23	UPTO 50.0mm - ±0.46	UPTO 160.0mm - ±1.02	
UPTO 12.0mm - ±0.25	UPTO 60.0mm - ±0.53	UPTO 200.0mm - ±1.14	
UPTO 16.0mm - ±0.28	UPTO 80.0mm - ±0.69	UPTO 250.0mm - ±1.40	
UPTO 25.0mm - ±0.30	UPTO 100.0mm - ±0.75	UPTO 300.0mm - ±1.65	



SYMBOL OF QUALITY  
AN ISO 9001 COMPANY

**JINDAL ALUMINIUM LTD.**  
BANGALORE-560073 (INDIA)

	NAME	DATE
DRAWN	PARVESH	20-08-2015
CHECKED		
APPROVED	S.S.GARG	24-08-2015

- ALL DIMENSIONS ARE IN mm.
- ROUND OFF ALL SHARP CORNERS WITH 0.40 mm.
- TOLERANCES WILL BE AS PER IS:6477-1983 , UNLESS OTHERWISE SPECIFIED

SCALE	1:1
AREA mm <sup>2</sup>	364.013
PERIMETER mm.	371.715
WEIGHT kg/m	0.983
DRAWING No.	SECTION No.
P-15076	-
S4606	S4606
21784	21784

PARTY'S NAME	KARAM DASS NIRASH , MUMBAI
PARTY'S DRAWING No.	AS PER AUTOCAD DRAWING-HW-13A
ALLOY & TEMPER	6063 T6
DESCRIPTION	WINDOW SECTION