

P-15761

S4907

21803

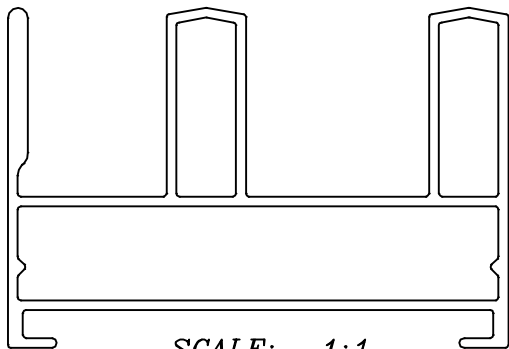
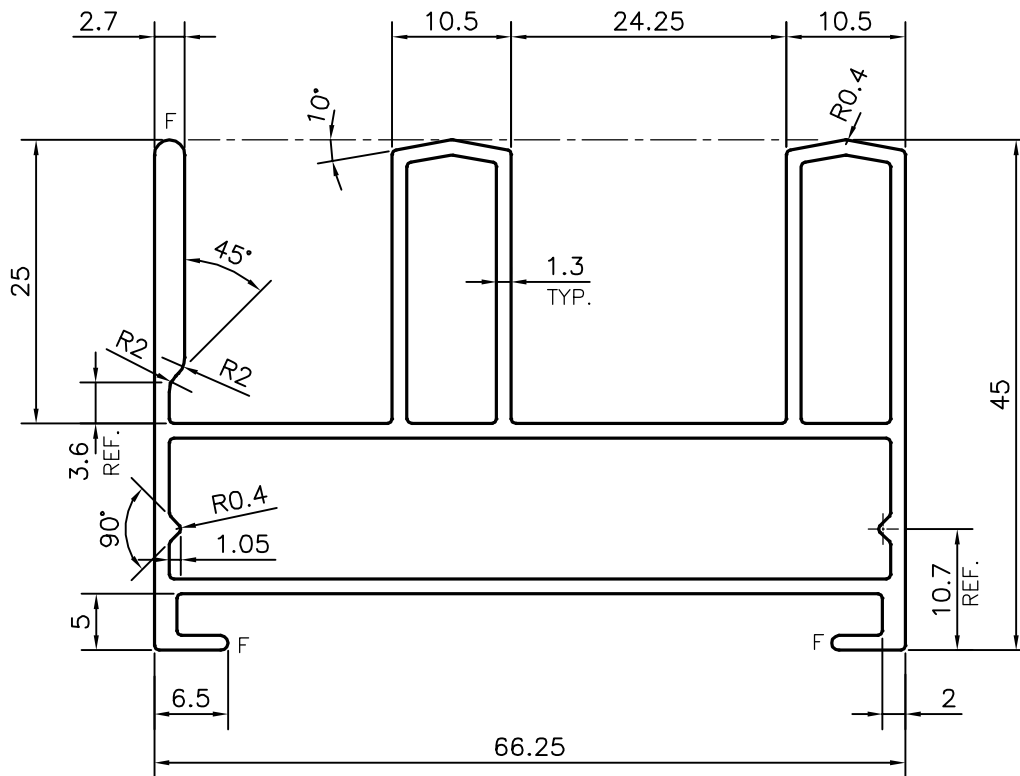

F = FULL RADIUS (3 PLACES)



SYMBOL OF QUALITY
AN ISO 9001 COMPANY

JINDAL ALUMINIUM LTD.
BANGALORE-560073 (INDIA)

	NAME	DATE
DRAWN	PARVESH	07-04-2016
CHECKED		
APPROVED	S.S. GARG	12-04-2016
SCALE		1.5:1
AREA mm ²		446.578
PERIMETER mm.		344.508
WEIGHT kg/m		1.206
DRAWING No.	SECTION No.	
P-15761	-	
S4907	S4907	
21803	21803	

1. ALL DIMENSIONS ARE IN mm.
2. ROUND OFF ALL SHARP CORNERS WITH 0.40 mm.
3. TOLERANCES WILL BE AS PER IS:6477-1983 , UNLESS OTHERWISE SPECIFIED

PARTY'S NAME	NEST, BANGALORE
PARTY'S DRAWING No.	AS PER REQUIREMENT
ALLOY & TEMPER	6063 T6
DESCRIPTION	WINDOW SECTION