

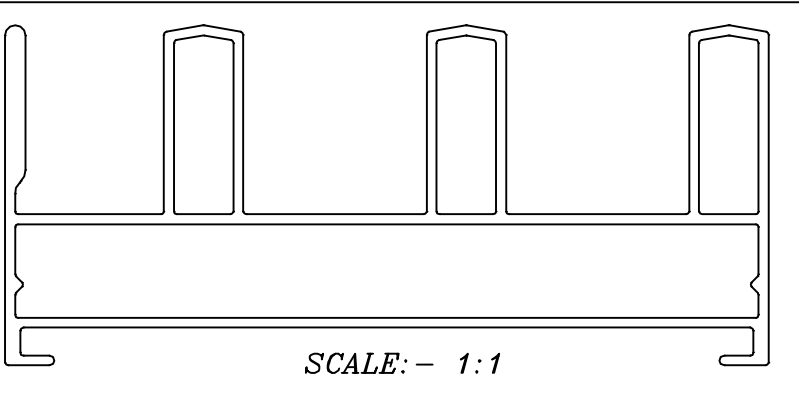

P-15762
S4908
21805

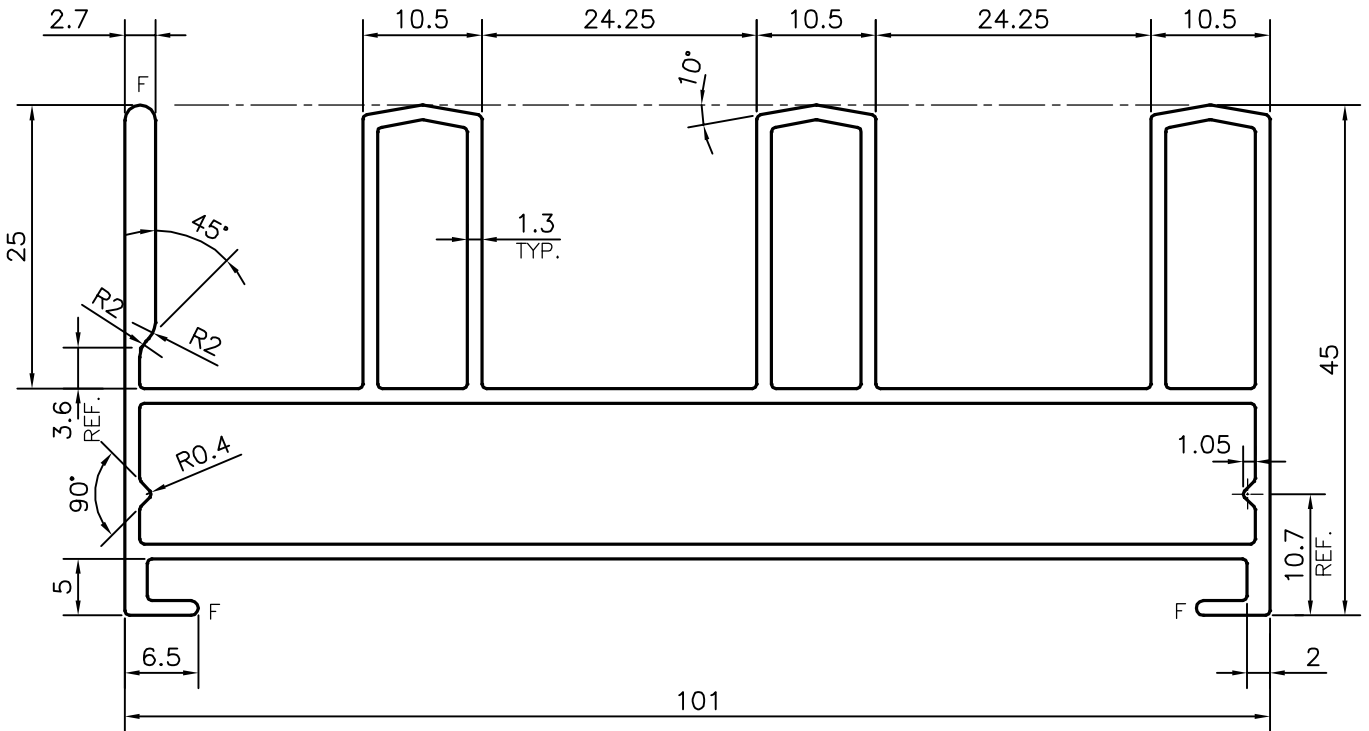

F = FULL RADIUS (3 PLACES)

 SYMBOL OF QUALITY AN ISO 9001 COMPANY	<b>JINDAL ALUMINIUM LTD.</b> BANGALORE-560073 (INDIA)	DRAWN	NAME	DATE
		CHECKED	PARVESH	07-04-2016
1. ALL DIMENSIONS ARE IN mm. 2. ROUND OFF ALL SHARP CORNERS WITH 0.40 mm. 3. TOLERANCES WILL BE AS PER IS:6477-1983 , UNLESS OTHERWISE SPECIFIED		APPROVED	S.S. GARG	12-04-2016
		SCALE		1.5:1
PARTY'S NAME NEST, BANGALORE		AREA	mm <sup>2</sup>	610.401
		PERIMETER	mm.	461.761
PARTY'S DRAWING No. AS PER REQUIREMENT		WEIGHT	kg/m	1.648
		DRAWING No.	SECTION No.	
ALLOY & TEMPER 6063 T6		P-15762	-	
		S4908	S4908	
DESCRIPTION WINDOW SECTION		21805	21805	