

P-15813

S4931

21809

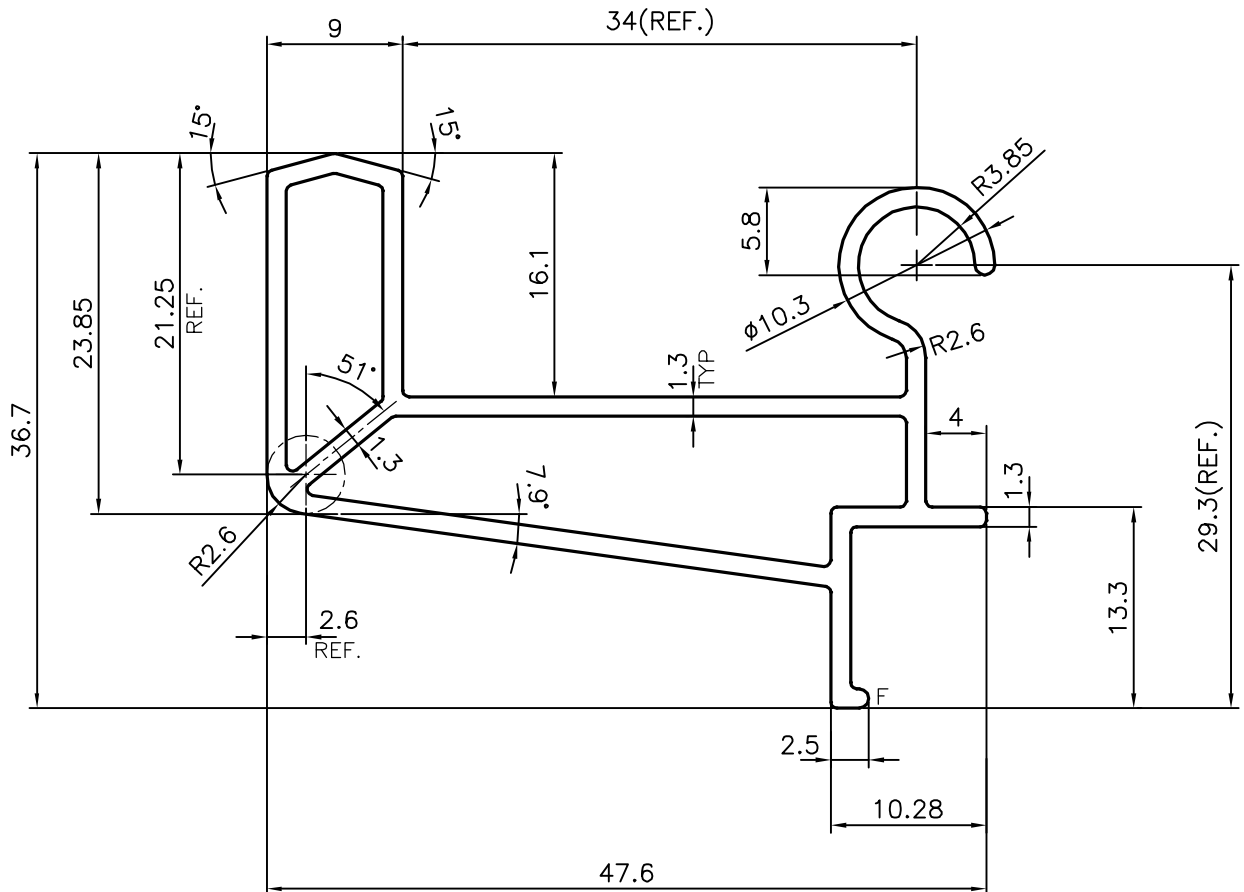
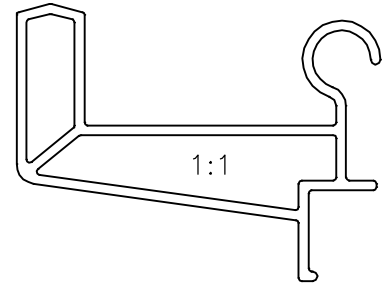
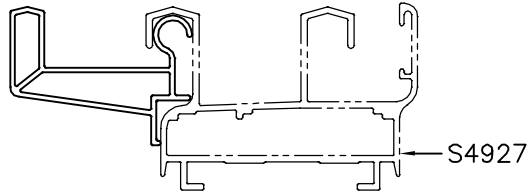

ASSEMBLY SECTION :- S4927,S4928,S4929,S4930

F = FULL RADIUS



SYMBOL OF QUALITY
AN ISO 9001 COMPANY

JINDAL ALUMINIUM LTD.
BANGALORE-560073 (INDIA)

	NAME	DATE
DRAWN	J.P.KAUSHIK	05-05-2016
CHECKED		
APPROVED	B. NATARAJ	06-05-2016
SCALE		2:1
AREA mm ²		232.651
PERIMETER mm.		211.419
WEIGHT kg/m		0.628
DRAWING No.	SECTION No.	
P-15813	-	
S4931	S4931	
21809	21809	

1. ALL DIMENSIONS ARE IN mm.
2. ROUND OFF ALL SHARP CORNERS WITH 0.40 mm.
3. TOLERANCES WILL BE AS PER IS:6477-1983, UNLESS OTHERWISE SPECIFIED

PARTY'S NAME	FULL SPACE INTERIORS, MUMBAI
PARTY'S DRAWING No.	AS PER AutoCAD DRAWING
ALLOY & TEMPER	HE9 WP
DESCRIPTION	MISC.SECTION