

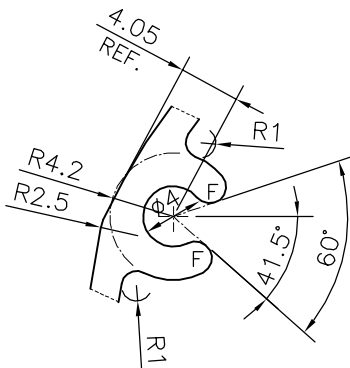

P-16379
S5088
21828

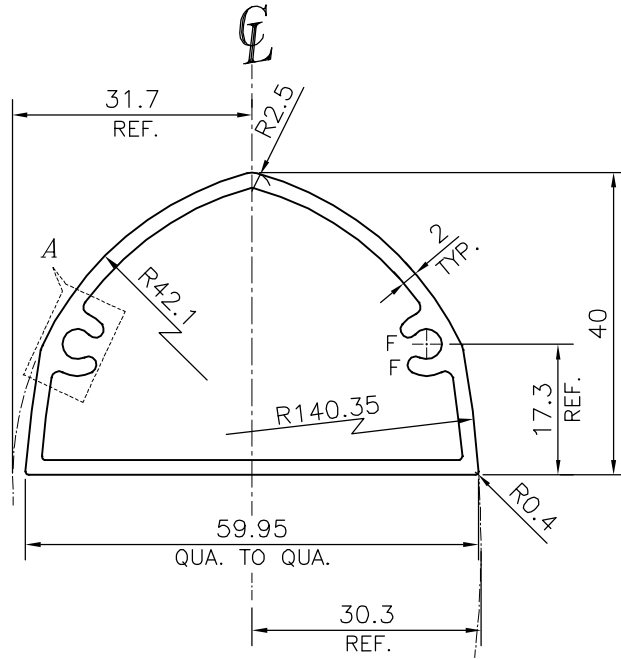

DETAIL OF "A"
SCALE 2:1

F = FULL RADIUS (4 PLACES)

 SYMBOL OF QUALITY AN ISO 9001 COMPANY	JINDAL ALUMINIUM LTD. BANGALORE-560073 (INDIA)	NAME	DATE
		DRAWN	PARVESH 20-09-2016
		CHECKED	
		APPROVED	S.S. GARG 24-09-2016
		SCALE	1:1
		AREA mm ²	370.735
		PERIMETER mm.	168.581
		WEIGHT kg/m	1.001
PARTY'S NAME	MARVEL TOUCH ALUMINIUM PVT. LTD., MUMBAI	DRAWING No.	SECTION No.
PARTY'S DRAWING No.	AS PER AUTOCAD DRAWING-FIN(B)	P-16379	-
ALLOY & TEMPER	6063 T6	S5088	S5088
DESCRIPTION	LOUVER SECTION	21828	21828