

P-19619

21877

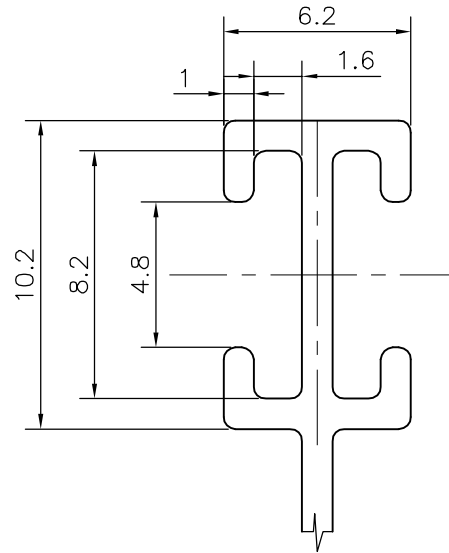

DETAILS OF "A"
SCALE 4:1

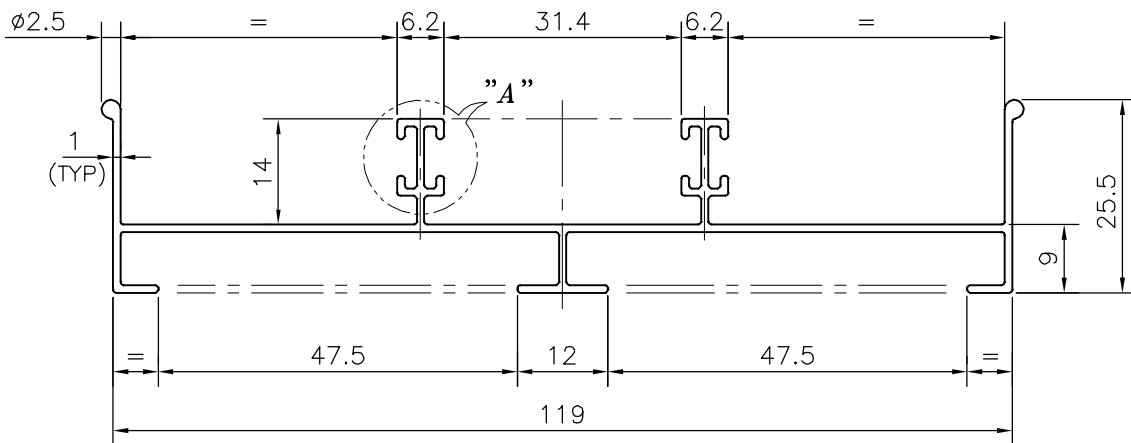

SYMBOL OF QUALITY
AN ISO 9001 COMPANY

JINDAL ALUMINIUM LTD.
BANGALORE-560073 (INDIA)

	NAME	DATE
DRAWN	J.P.KAUSHIK	05-06-2019
CHECKED		
APPROVED	B.NATARAJA	25-06-2019
SCALE		1:1
AREA	mm ²	264.952
PERIMETER	mm.	511.577
WEIGHT	kg/m	0.715
DRAWING No.	SECTION No.	
P-19619	-	
21877	21877	

1. ALL DIMENSIONS ARE IN mm.
2. ROUND OFF ALL SHARP CORNERS WITH 0.40 mm.
3. TOLERANCES WILL BE AS PER BS:EN-755-9, UNLESS OTHERWISE SPECIFIED

PARTY'S NAME	PRAYOSHA ENTERPRISES LTD., UGANDA
PARTY'S DRAWING No.	MODIFIED OF 21440
ALLOY & TEMPER	6063 T6
DESCRIPTION	WINDOW SECTION (3 TRACK VERTICAL)