

P-19212-1

21880

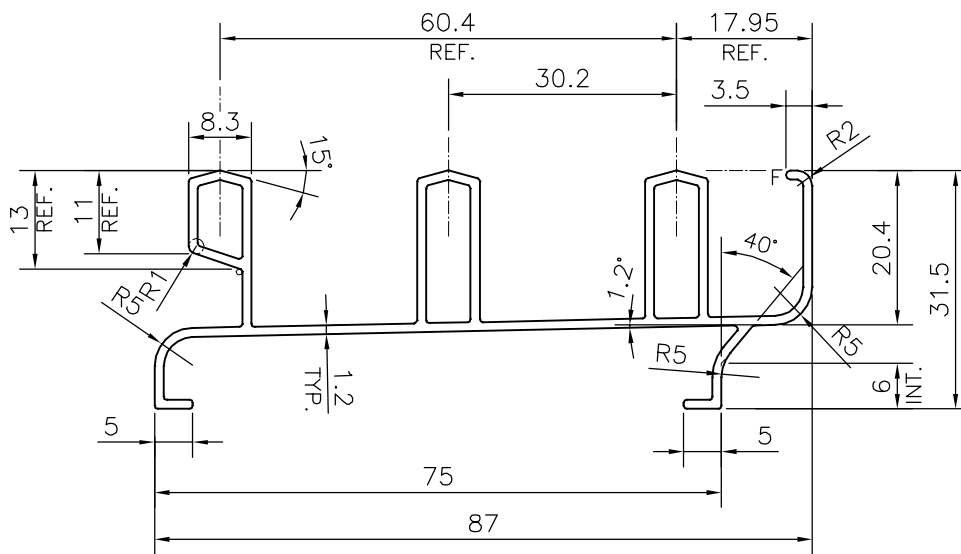

F = FULL RADIUS (1 PLACE)



SYMBOL OF QUALITY
AN ISO 9001 COMPANY

JINDAL ALUMINIUM LTD.
BANGALORE-560073 (INDIA)

	NAME	DATE
DRAWN	J.P.KAUSHIK	12-03-2019
CHECKED		
APPROVED	B.NATARAJA	08-07-2019
SCALE		1:1
AREA	mm ²	316.089
PERIMETER	mm.	391.456
WEIGHT	kg/m	0.853
DRAWING No.	SECTION No.	
P-19212-1	-	
21880	21880	

1. ALL DIMENSIONS ARE IN mm.
2. ROUND OFF ALL SHARP CORNERS WITH 0.4 mm.
3. TOLERANCES WILL BE AS PER IS:6477-1983 , UNLESS OTHERWISE SPECIFIED

PARTY'S NAME	GENERAL CATEGORY, MUMBAI MARKET
PARTY'S DRAWING No.	AS PER DRAWING
ALLOY & TEMPER	HE9 WP
DESCRIPTION	WINDOW SECTION