

P-19746

21887

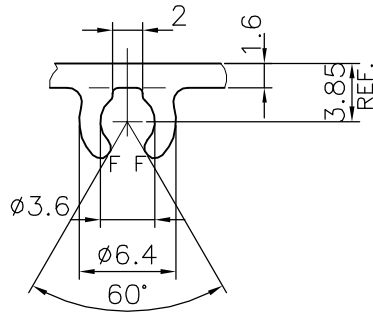

DETAIL OF "B"
SCALE 2:1

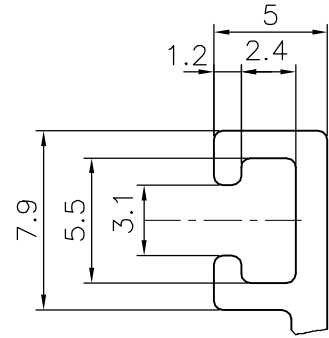

DETAIL OF "A"
SCALE 3:1

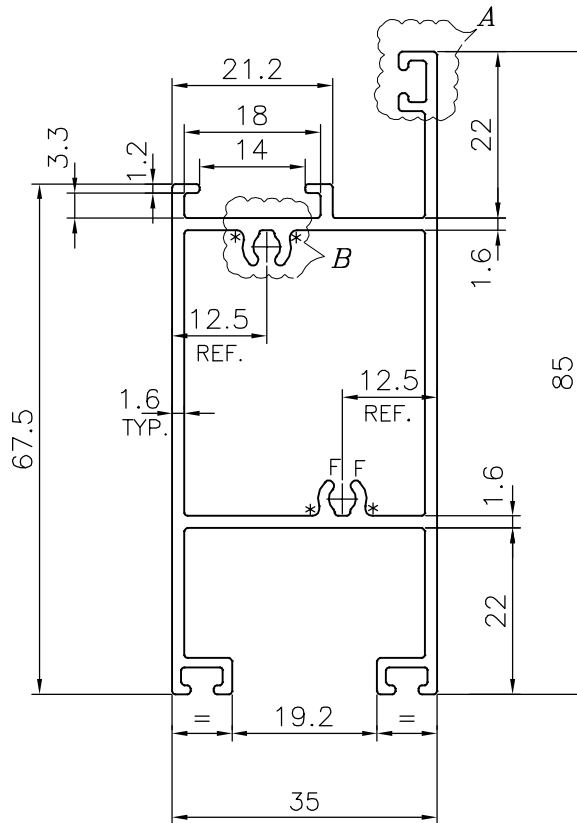

* = 1.0 RADIUS (4 PLACES)
F = FULL RADIUS (4 PLACES)



SYMBOL OF QUALITY
AN ISO 9001 COMPANY

JINDAL ALUMINIUM LTD.
BANGALORE-560073 (INDIA)

	NAME	DATE
DRAWN	J.P.KAUSHIK	02-07-2019
CHECKED		
APPROVED	J.N.RAI	17-07-2019
SCALE		1:1
AREA mm ²		424.359
PERIMETER mm.		369.416
WEIGHT kg/m		1.146
DRAWING No.	SECTION No.	
P-19746	-	
21887	21887	

1. ALL DIMENSIONS ARE IN mm.
2. ROUND OFF ALL SHARP CORNERS WITH 0.40 mm.
3. TOLERANCES WILL BE AS PER BS:EN-755-9, UNLESS OTHERWISE SPECIFIED

PARTY'S NAME	VARINDERA CONSTRUCTIONS LTD., MAURITIUS
PARTY'S DRAWING No.	AS PER DRAWING-D5
ALLOY & TEMPER	6063 T6
DESCRIPTION	WINDOW SECTION