

P-17470
X2263
21914

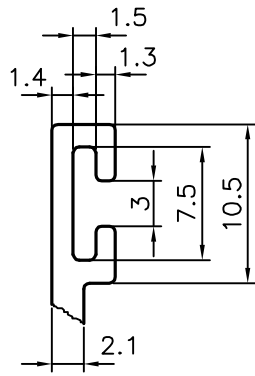

DETAIL OF "A"
SCALE 2:1

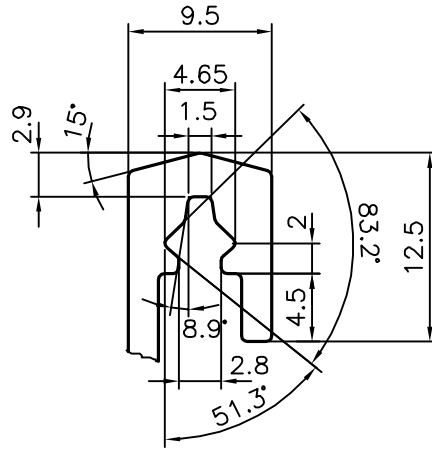

DETAIL OF "B"
SCALE 2:1

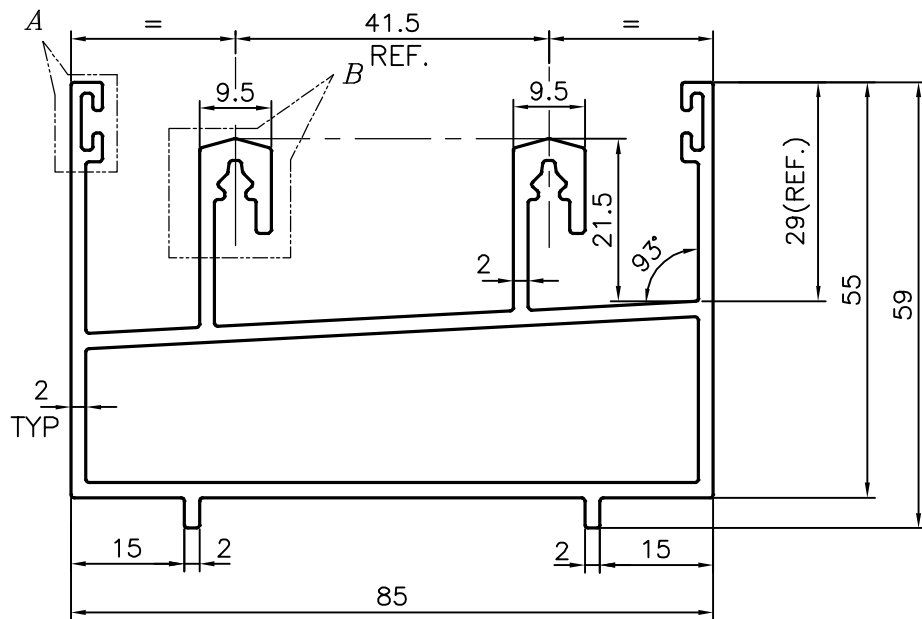

TOLERANCES ON OVERALL DIMENSIONS OF HOLLOW SECTIONS

UPTO 20.0mm - ±0.30	UPTO 80.0mm - ±0.70	UPTO 180.0mm - ±1.27	1. STRAIGHTNESS=1.7mm/M 2. TWIST=1.7mm/M 3. ANGULARITY= ±2° 4. FLATNESS =0.006xWIDTH
UPTO 30.0mm - ±0.38	UPTO 100.0mm - ±0.80	UPTO 200.0mm - ±1.40	
UPTO 40.0mm - ±0.45	UPTO 120.0mm - ±0.90	UPTO 225.0mm - ±1.52	
UPTO 50.0mm - ±0.52	UPTO 140.0mm - ±1.00		
UPTO 60.0mm - ±0.60	UPTO 160.0mm - ±1.14		

 SYMBOL OF QUALITY AN ISO 9001 COMPANY	JINDAL ALUMINIUM LTD. BANGALORE-560073 (INDIA)	DRAWN	NAME	DATE
		CHECKED	J.P.KAUSHIK	25-10-2017
1. ALL DIMENSIONS ARE IN mm. 2. ROUND OFF ALL SHARP CORNERS WITH 0.40 mm. 3. TOLERANCES WILL BE AS PER IS:6477-1983 , UNLESS OTHERWISE SPECIFIED		APPROVED	B.NATARAJA	26-10-2017
		SCALE		1:1
PARTY'S NAME		AREA mm ²		768.381
		PERIMETER mm.		547.037
PARTY'S DRAWING No.		WEIGHT kg/m		2.075
		DRAWING No.	SECTION No.	
ALLOY & TEMPER		P-17470		-
		X2263		X2263
DESCRIPTION		21914		21914
		2 TRACK VERTICAL & TOP PROFILE		