

P-20813

21919

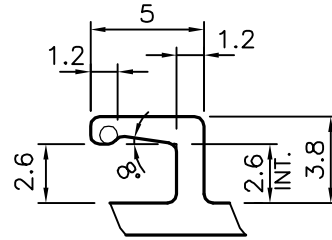

DETAIL OF "A"
SCALE 3:1

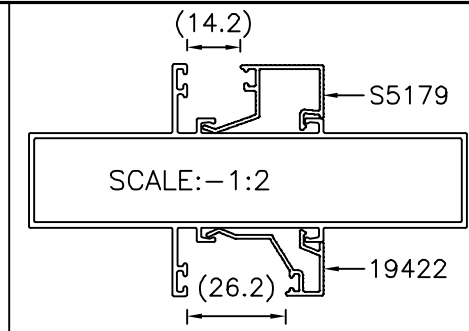
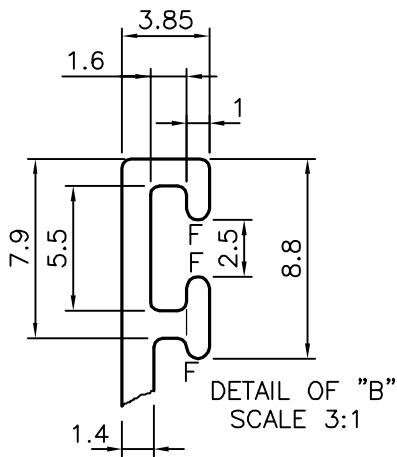
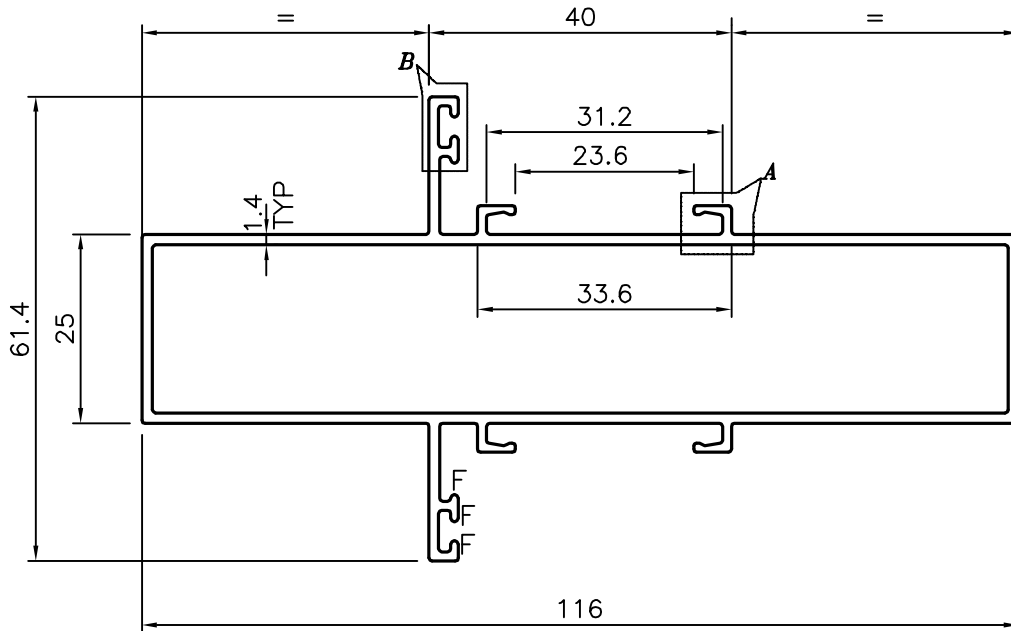

F = FULL RADIUS (6 PLACES)

TOLERANCES ON OVERALL WIDTHS & WIDTHS ACROSS FLATS OF BARS, & REGULAR SECTIONS

UPTO 6.40mm - ±0.20	UPTO 32.0mm - ±0.38	UPTO 120.0mm - ±0.85	UPTO 320.00mm - ±1.70
UPTO 10.0mm - ±0.23	UPTO 50.0mm - ±0.46	UPTO 160.0mm - ±1.02	
UPTO 12.0mm - ±0.25	UPTO 60.0mm - ±0.53	UPTO 200.0mm - ±1.14	
UPTO 16.0mm - ±0.28	UPTO 80.0mm - ±0.69	UPTO 250.0mm - ±1.40	
UPTO 25.0mm - ±0.30	UPTO 100.0mm - ±0.75	UPTO 300.0mm - ±1.65	

 SYMBOL OF QUALITY AN ISO 9001 COMPANY	JINDAL ALUMINIUM LTD. BANGALORE-560073 (INDIA)	DRAWN	NAME	DATE
		CHECKED	J.P.KAUSHIK	24-02-2020
1. ALL DIMENSIONS ARE IN mm. 2. ROUND OFF ALL SHARP CORNERS WITH 0.40 mm. 3. TOLERANCES WILL BE AS PER IS:6477-1983 UNLESS OTHERWISE SPECIFIED		APPROVED	B.NATARAJA	27-02-2020
		SCALE		1:1
PARTY'S NAME SUMIT CORPORATION, BHIWANDI		AREA mm ²		490.059
		PERIMETER mm.		441.292
PARTY'S DRAWING No. AS PER DRAWING		WEIGHT kg/m		1.323
		DRAWING No.	SECTION No.	
ALLOY & TEMPER 6063 T6		P-20813		-
		21919		21919
DESCRIPTION WINDOW SECTION				