

P-21602-1

21943

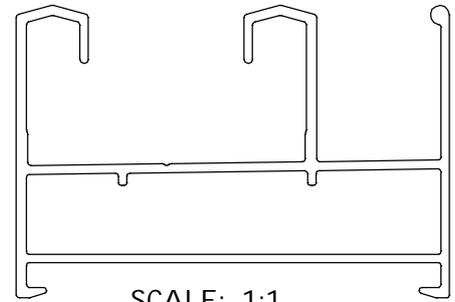

SCALE:- 1:1

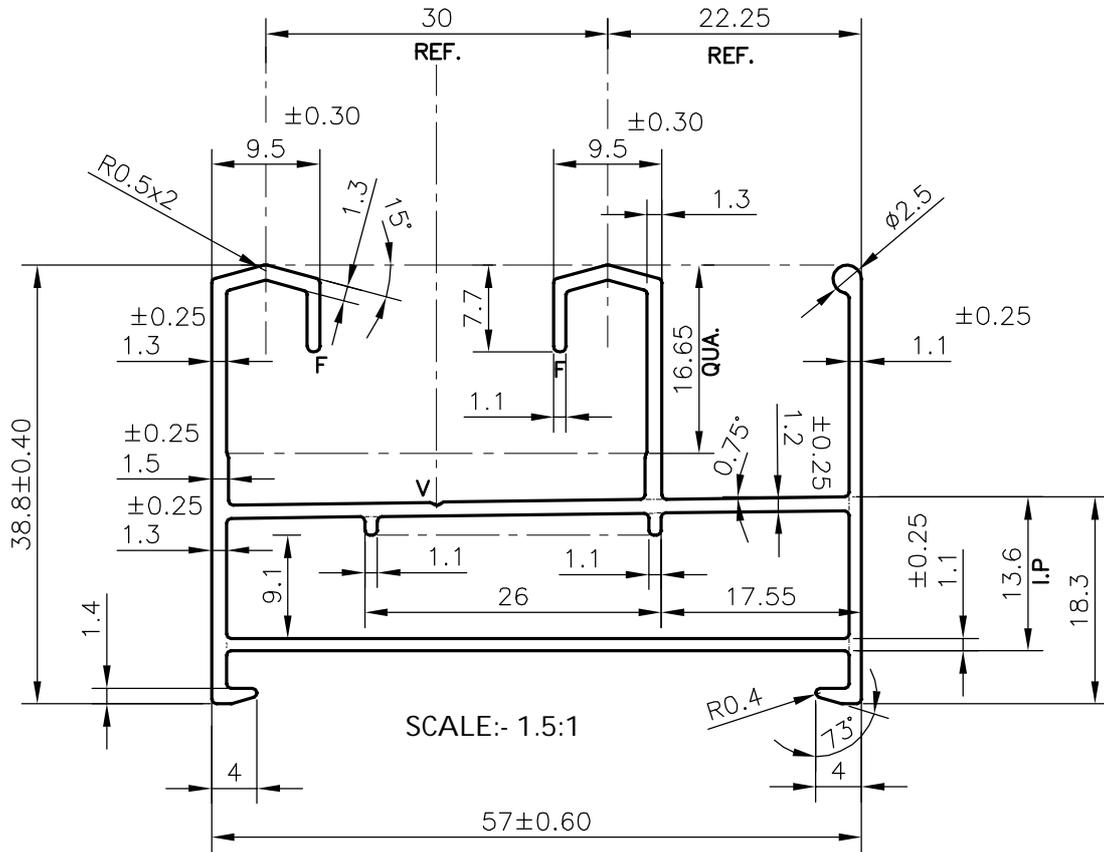

SCALE:- 1.5:1

WEIGHT RANGE (kg/m) - 0.707 - 0.864 (APPROX.)

**F = FULL RADIUS (2 PLACES)
V="V" GROOVE 0.3x90° (1 PLACE)**

TOLERANCES ON OVERALL DIMENSIONS OF HOLLOW SECTIONS

UPTO 20.0mm - ±0.30	UPTO 80.0mm - ±0.70	UPTO 180.0mm - ±1.27	1. STRAIGHTNESS=1.7mm/M 2. TWIST=1.7mm/M 3. ANGULARITY= ±2° 4. FLATNESS =0.006xWIDTH
UPTO 30.0mm - ±0.38	UPTO 100.0mm - ±0.80	UPTO 200.0mm - ±1.40	
UPTO 40.0mm - ±0.45	UPTO 120.0mm - ±0.90	UPTO 225.0mm - ±1.52	
UPTO 50.0mm - ±0.52	UPTO 140.0mm - ±1.00		
UPTO 60.0mm - ±0.60	UPTO 160.0mm - ±1.14		



SYMBOL OF QUALITY
AN ISO 9001 COMPANY

JINDAL ALUMINIUM LTD.
BANGALORE-560073 (INDIA)

	NAME	DATE
DRAWN	DARPAN	03-10-2020
CHECKED		
APPROVED	B.NATARAJA	09-10-2020
SCALE		1.5:1
AREA mm ²		290.689
PERIMETER mm.		341.816
WEIGHT kg/m		0.785
DRAWING No.		SECTION No.
P-21602-1		-
21943		21943

- ALL DIMENSIONS ARE IN mm.
- ROUND OFF ALL SHARP CORNERS WITH 0.40 mm.
- TOLERANCES WILL BE AS PER IS:6477-1983, UNLESS OTHERWISE SPECIFIED

PARTY'S NAME	MAROR'S ALUMINIUM & INTERIORS, MANGALORE
PARTY'S DRAWING No.	AS PER AutoCAD DRAWING
ALLOY & TEMPER	6063 T6
DESCRIPTION	WINDOW 2 TRACK SECTION