

P-18154

S5921

21946

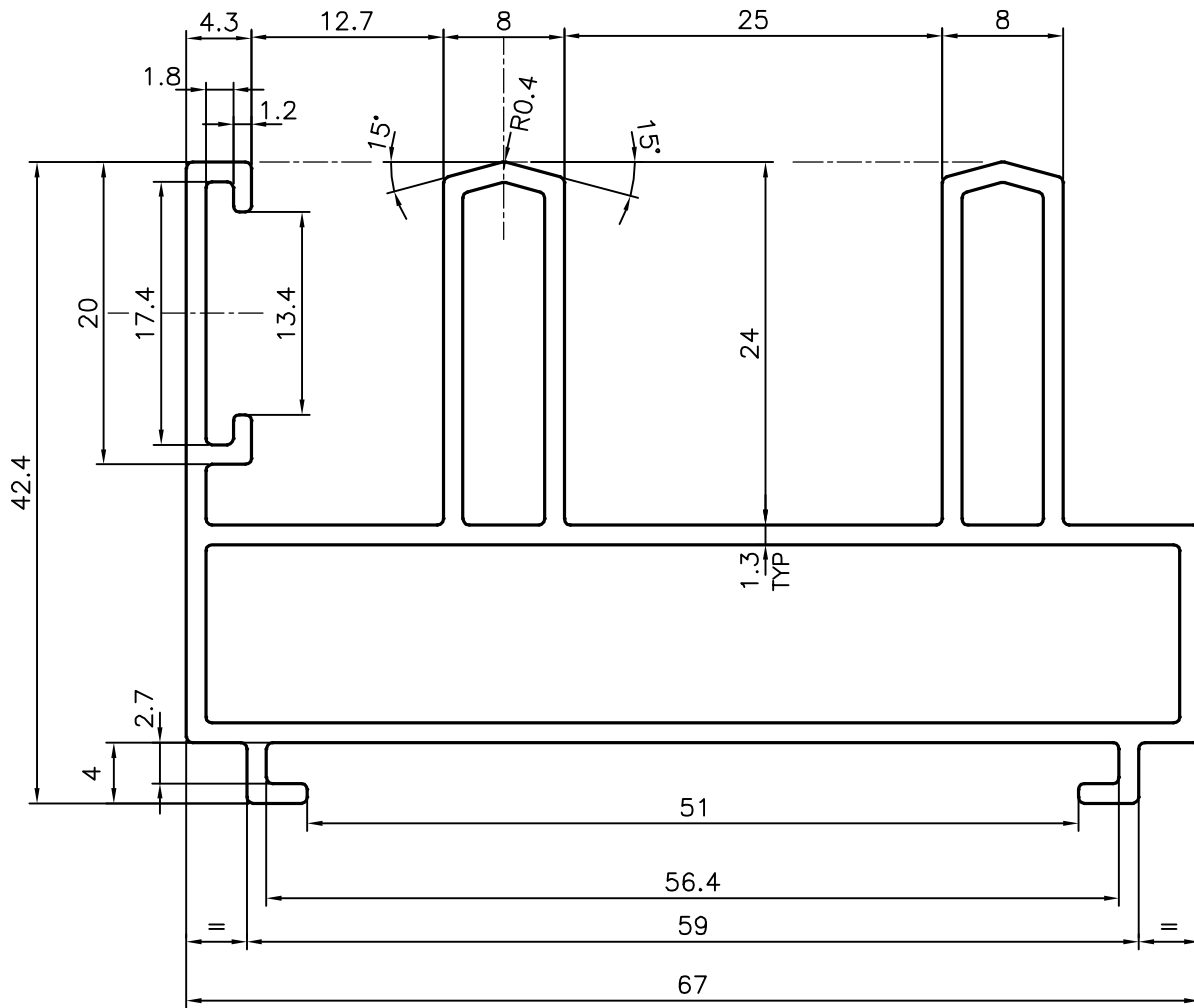
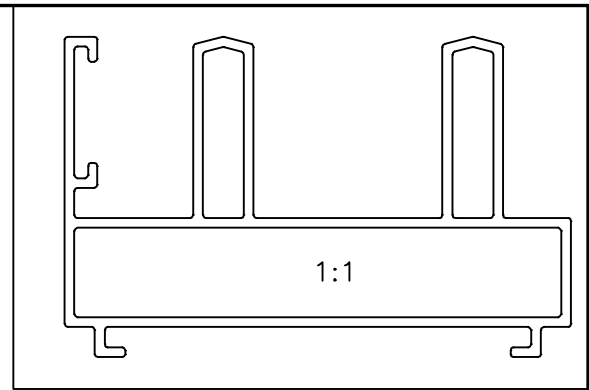

SYMBOL OF QUALITY
AN ISO 9001 COMPANY

JINDAL ALUMINIUM LTD.
BANGALORE-560073 (INDIA)

	NAME	DATE
DRAWN	J.P.KAUSHIK	27-04-2018
CHECKED		
APPROVED	B.NATARAJA	14-07-2018
SCALE		2:1
AREA mm ²		401.116
PERIMETER mm.		344.069
WEIGHT kg/m		1.083
DRAWING No.	SECTION No.	
P-18154	-	
S5921	S5921	
21946	21946	

1. ALL DIMENSIONS ARE IN mm.
2. ROUND OFF ALL SHARP CORNERS WITH 0.40 mm.
3. TOLERANCES WILL BE AS PER IS:6477-1983 , UNLESS OTHERWISE SPECIFIED

PARTY'S NAME	FULL SPACE INTERIORS, MUMBAI
PARTY'S DRAWING No.	FSI-AL-DIE-21
ALLOY & TEMPER	6063 T6
DESCRIPTION	2 TRACK TOP & BOTTOM SECTION