

P-18155

S5922

21947

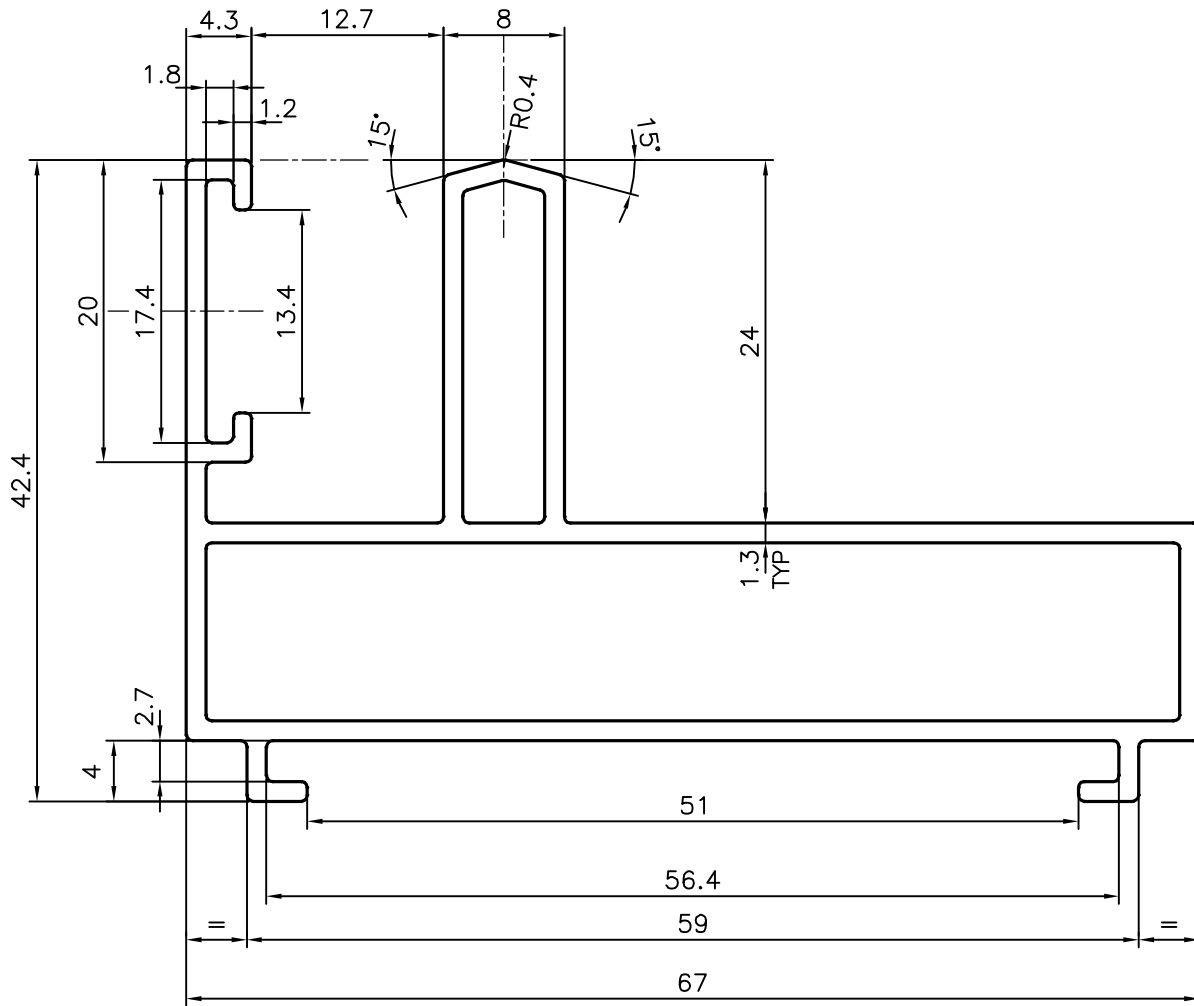
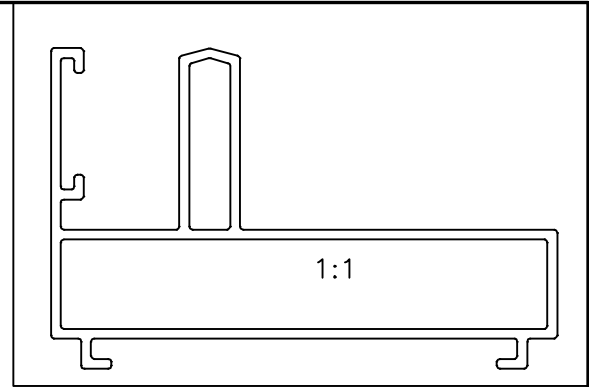

SYMBOL OF QUALITY
AN ISO 9001 COMPANY

JINDAL ALUMINIUM LTD.
BANGALORE-560073 (INDIA)

	NAME	DATE
DRAWN	J.P.KAUSHIK	27-04-2018
CHECKED		
APPROVED	B.NATARAJA	14-07-2018
SCALE		2:1
AREA mm ²		333.608
PERIMETER mm.		298.431
WEIGHT kg/m		0.901
DRAWING No.	SECTION No.	
P-18155	-	
S5922	S5922	
21947	21947	

1. ALL DIMENSIONS ARE IN mm.
2. ROUND OFF ALL SHARP CORNERS WITH 0.40 mm.
3. TOLERANCES WILL BE AS PER IS:6477-1983 , UNLESS OTHERWISE SPECIFIED

PARTY'S NAME	FULL SPACE INTERIORS, MUMBAI
PARTY'S DRAWING No.	FSI-AL-DIE-23
ALLOY & TEMPER	6063 T6
DESCRIPTION	SIDE SECTION-(WINDOW SECTION)