

P-22353

21978

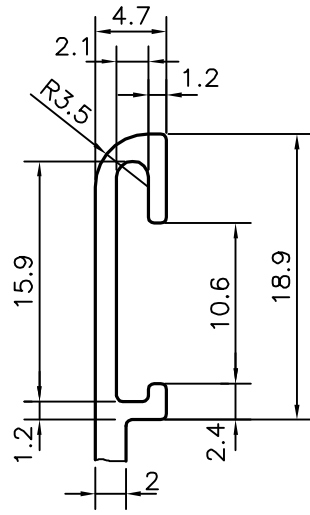

MATCHING SHUTTER 21977 & 41547

DETAILS OF "A"
SCALE 2:1

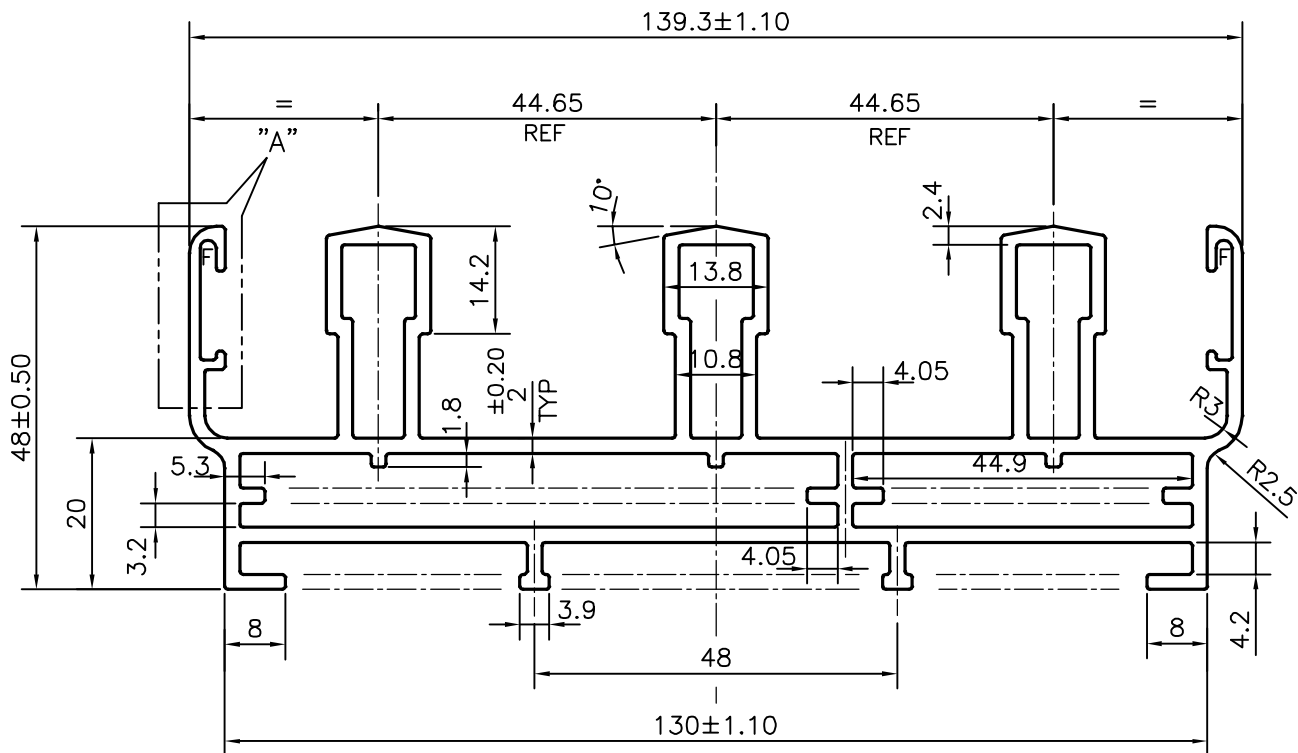

APPROXIMATE WEIGHT RANGE-2.994 - 3.660kg/m

F = FULL RADIUS (2 PLACES)

 SYMBOL OF QUALITY AN ISO 9001 COMPANY	JINDAL ALUMINIUM LTD. BANGALORE-560073 (INDIA)	NAME	DATE
		DRAWN	J.P.KAUSHIK 25-03-2021
		CHECKED	
		APPROVED	B.NATARAJA 21-04-2021
1. ALL DIMENSIONS ARE IN mm. 2. ROUND OFF ALL SHARP CORNERS WITH 0.40 mm. 3. TOLERANCES WILL BE AS PER IS:6477-1983 , UNLESS OTHERWISE SPECIFIED		SCALE	1:1
		AREA mm ²	1232.063
		PERIMETER mm.	699.808
		WEIGHT kg/m	3.327
PARTY'S NAME	KRISHNA AGENCIES, HYDERABAD	DRAWING No.	SECTION No.
PARTY'S DRAWING No.	HEAVIER OF 21480	P-22353	-
ALLOY & TEMPER	6063 T6	21978	21978
DESCRIPTION	WINDOW SHUTTER SECTION		