

P-22418

21979

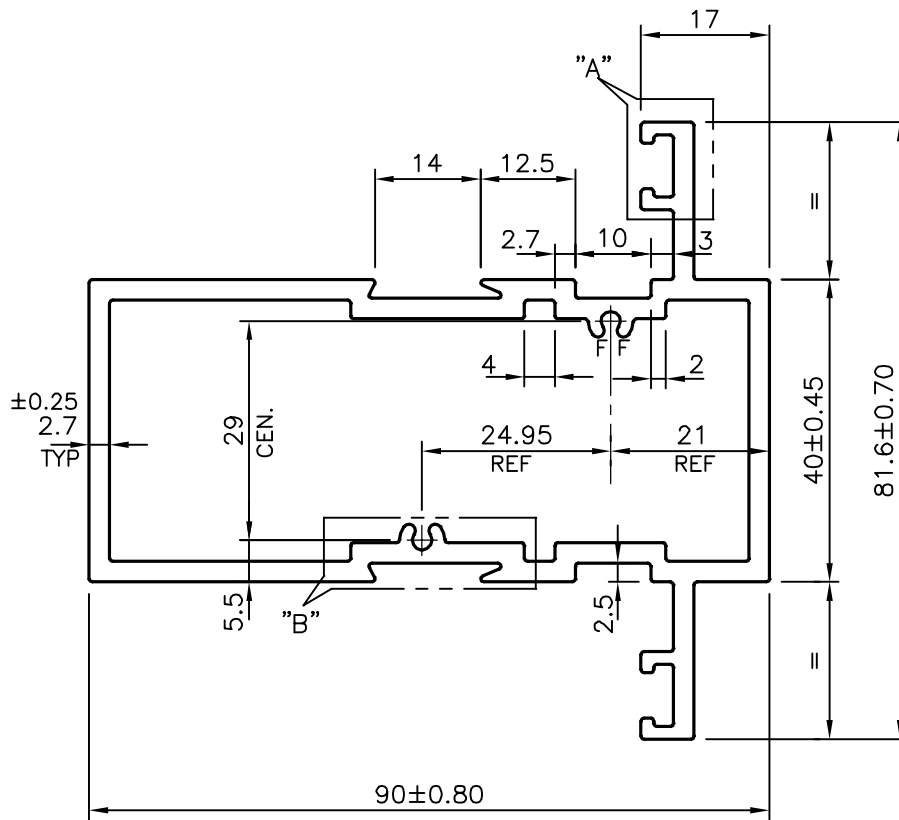
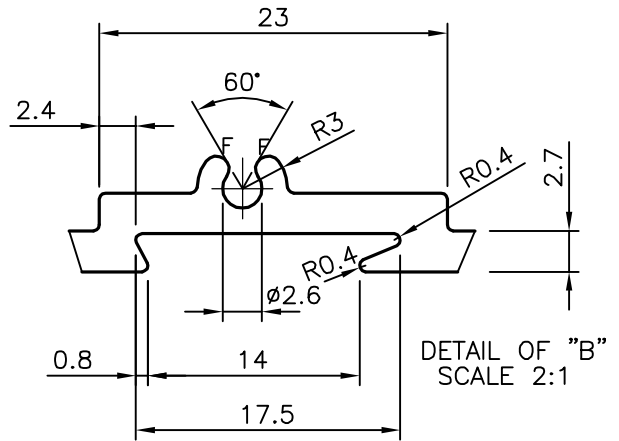
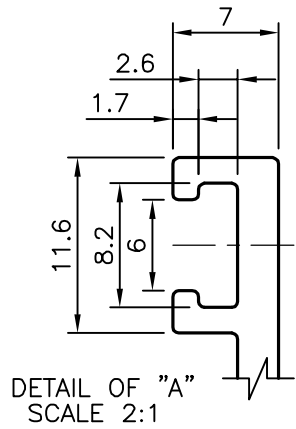

APPROXIMATE WEIGHT RANGE - 2.173 - 2.655 kg/m

F = FULL RADIUS (4 PLACES)



SYMBOL OF QUALITY
AN ISO 9001 COMPANY

JINDAL ALUMINIUM LTD.
BANGALORE-560073 (INDIA)

	NAME	DATE
DRAWN	J.P.KAUSHIK	09-04-2021
CHECKED		
APPROVED	B.NATARAJA	30-04-2021

1. ALL DIMENSIONS ARE IN mm.
2. ROUND OFF ALL SHARP CORNERS WITH 0.40 mm.
3. TOLERANCES WILL BE AS PER IS:6477-1983 UNLESS OTHERWISE SPECIFIED

SCALE	1:1
AREA mm ²	893.963
PERIMETER mm.	408.841
WEIGHT kg/m	2.414

PARTY'S NAME	MAHARASHTRA ALUMINIUM CENTRE, MUMBAI
PARTY'S DRAWING No.	AS PER DRAWING
ALLOY & TEMPER	6063 T6
DESCRIPTION	WINDOW SECTION

DRAWING No.	SECTION No.
P-22418	-
21979	21979