

2761

22007

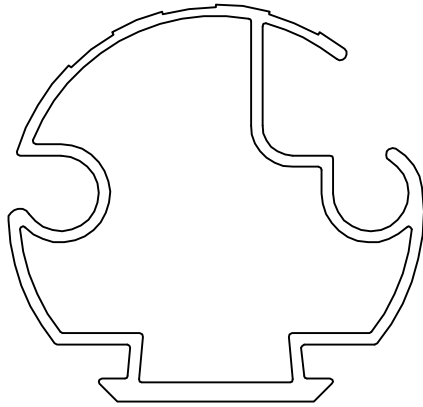

1:1

UNSPECIFIED WALL THICKNESS:- 1.50 mm.
F = FULL RADIUS (3)

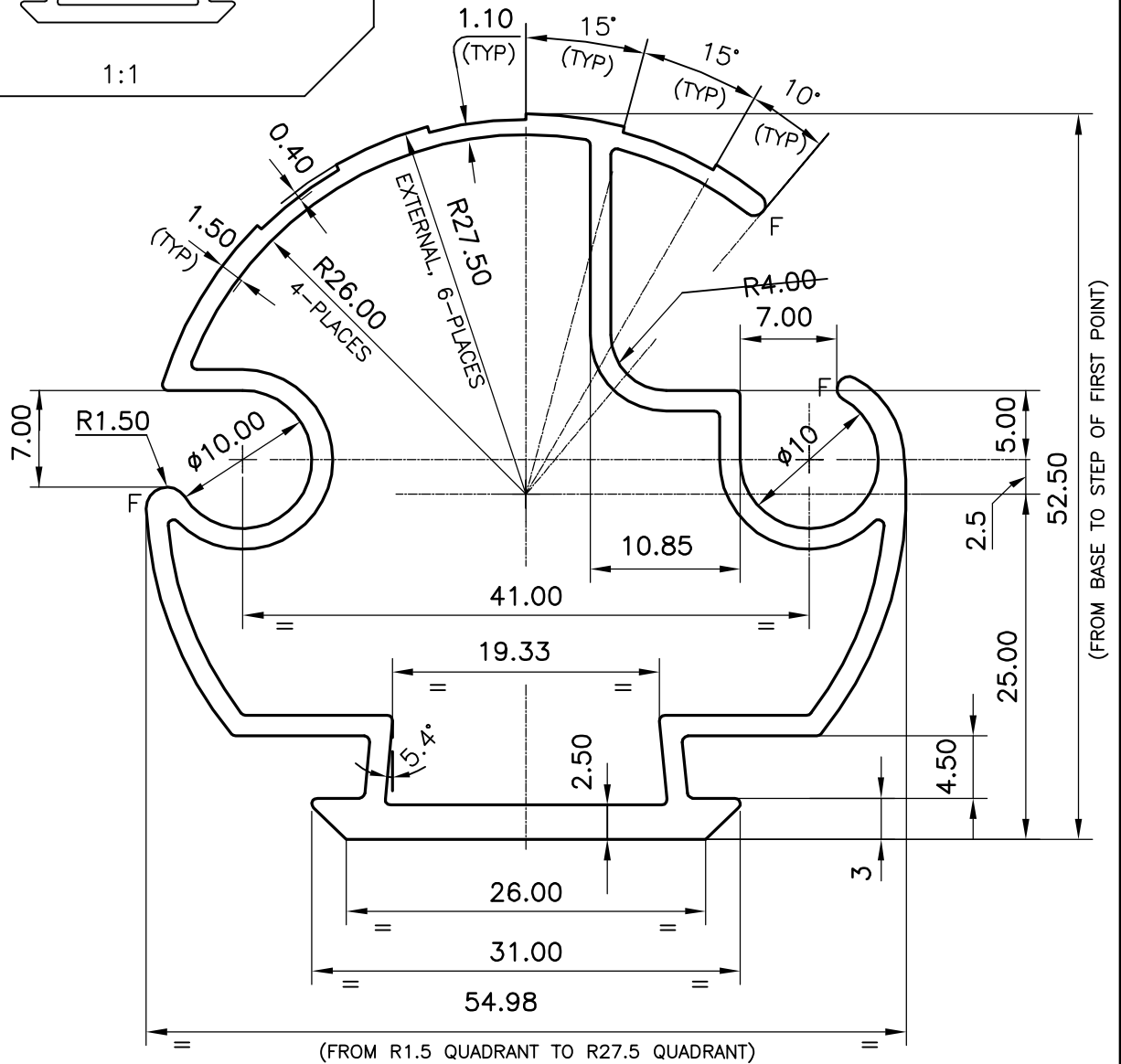

JINDAL ALUMINIUM LTD.
BANGALORE-560073

NAME

DATE

DRAWN

P,KULKARNI

31-5-99

CHECKED

APPROVED

1. ALL DIMENSIONS ARE IN mm.
2. ROUND OFF ALL SHARP CORNERS WITH 0.4 mm.
3. TOLERANCES WILL BE AS PER IS: 6477-1983 UNLESS OTHERWISE SPECIFIED

PARTY'S NAME

GENERAL CATEGORY-DELHI MARKET

SCALE

2:1

PARTY'S DRAWING No.

NIL

WEIGHT kg/m

1.028

ALLOY & TEMPER

HE9 WP

SECTION No.

22007

LENGTH

AS PER REQUIREMENTS

DRAWING No.

DESCRIPTION

MISCELLANEOUS TUBE

22007