

2770

22009

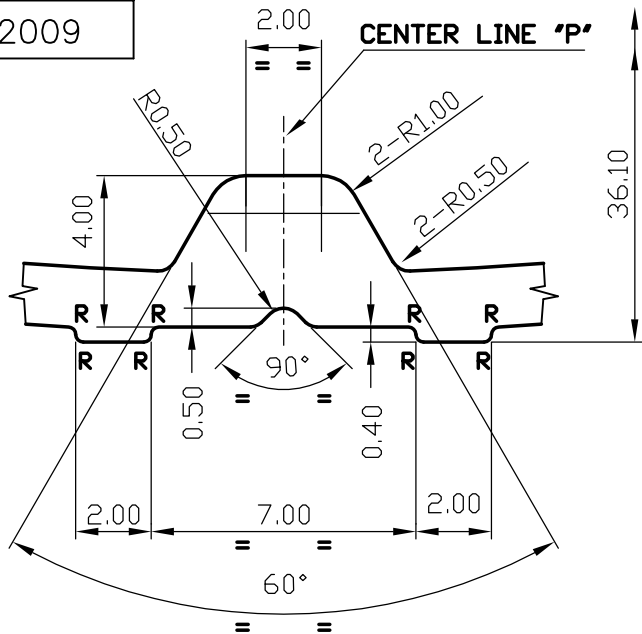

DETAILS "A"
SCALE = 5:1
R = RADII 0.20 (8)

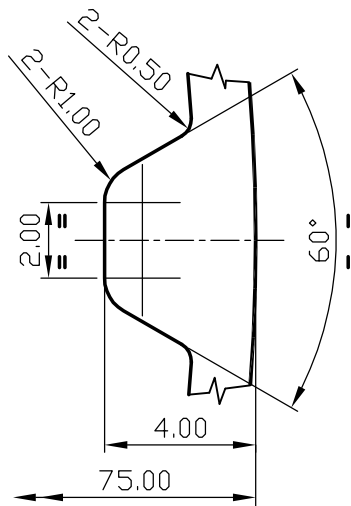

DETAILS "D"
SCALE = 5:1

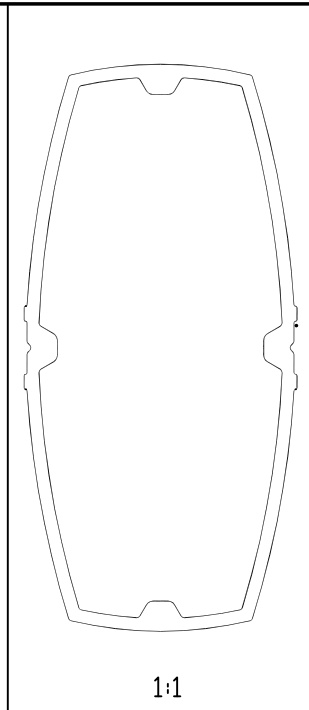

1:1

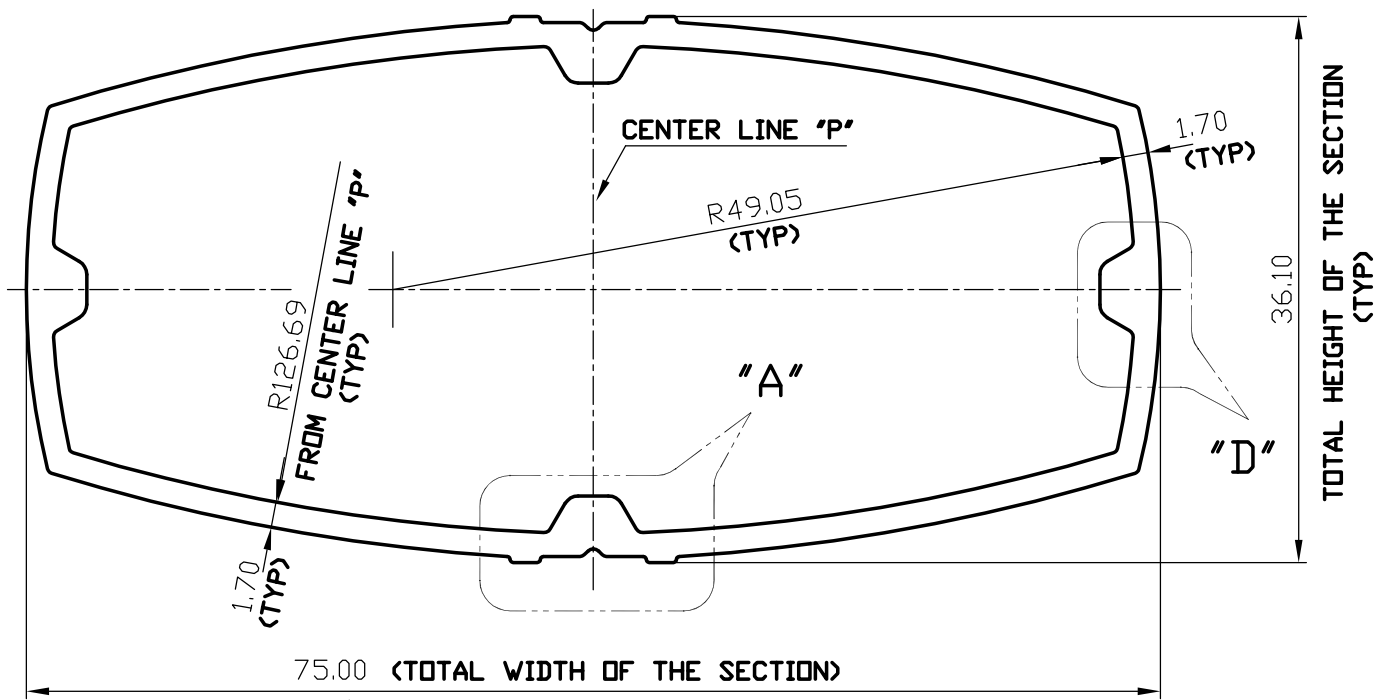

 SYMBOL OF QUALITY AN ISO 9002 COMPANY	JINDAL ALUMINIUM LTD. BANGALORE-560073 (INDIA)		NAME	DATE
			DRAWN	P,KULKARNI
1. ALL DIMENSIONS ARE IN mm. 2. ROUND OFF ALL SHARP CORNERS WITH 0.40 mm. 3. TOLERANCES WILL BE AS PER I.S. 6477-1983 UNLESS OTHERWISE SPECIFIED			CHECKED	
			APPROVED	
			SCALE	1:1
PARTY'S NAME	GENERAL CATEGORY., (DELHI MARKET)		WEIGHT kg/m	0.983
PARTY'S DRAWING No.	AS PER SAMPLE		SECTION No.	22009
ALLOY & TEMPER	HE9 WP	LENGTH: 3658 mm	DRAWING No.	
DESCRIPTION	MISC TUBE		22009	