

2780

22010

NOTE:

1. GENERAL WALL THICKNESS 1.25mm
2. F=FULL RADIUS (3)

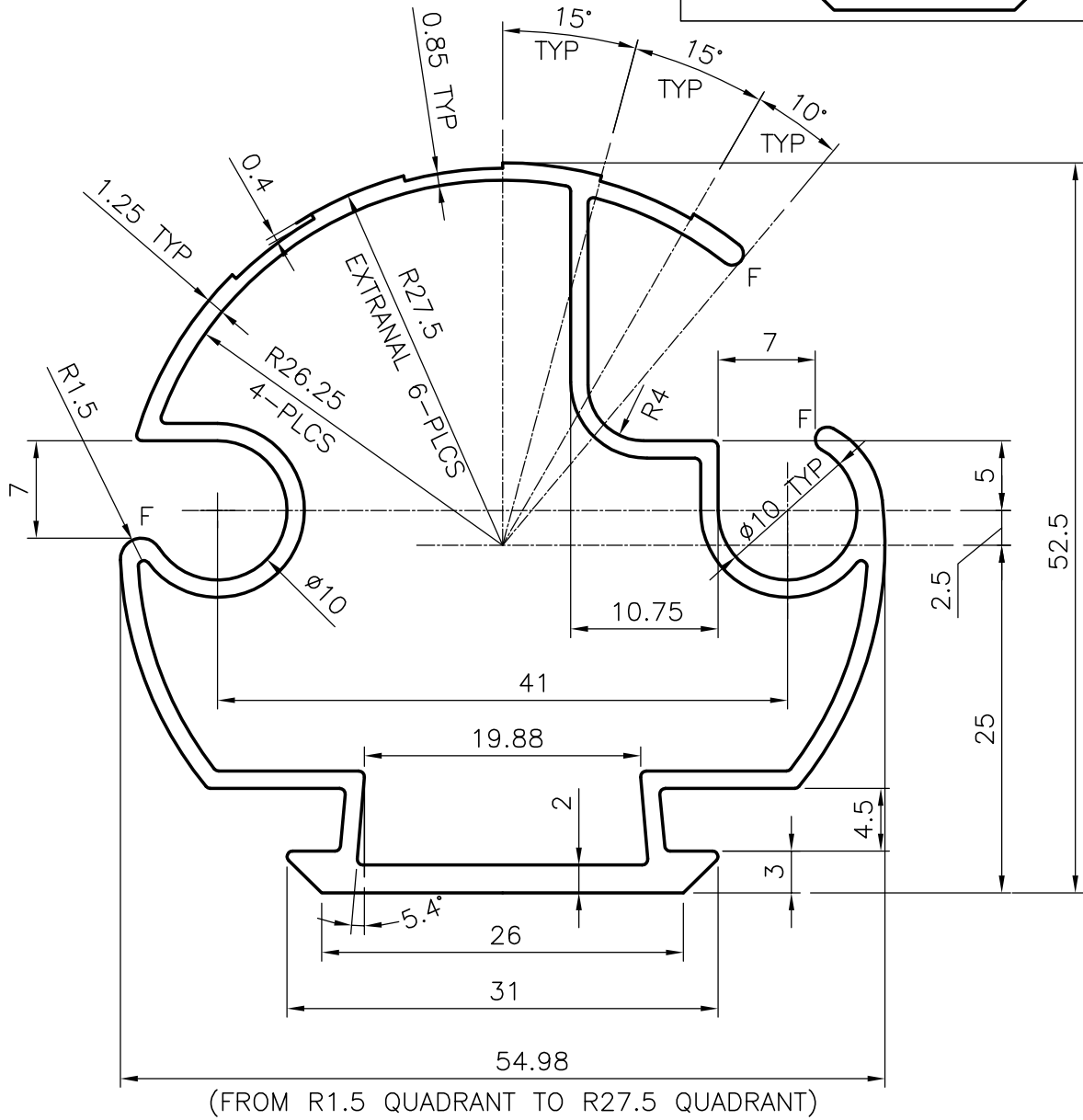
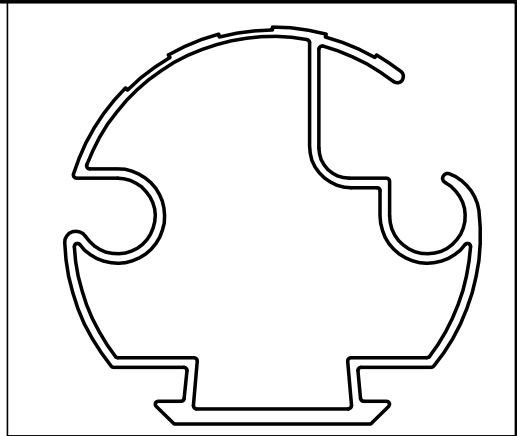

SYMBOL OF QUALITY  
AN ISO 9002 COMPANY

**JINDAL ALUMINIUM LTD.**  
**BANGALORE-560073 (INDIA)**

	NAME	DATE
DRAWN	RANGASWAMY	12-01-01
CHECKED		
APPROVED		

1. ALL DIMENSIONS ARE IN mm.
2. ROUND OFF ALL SHARP CORNERS WITH 0.40 mm.
3. TOLERANCES WILL BE AS PER IS 6477-1983 UNLESS OTHERWISE SPECIFIED

PARTY'S NAME	GENERAL CATEGORY ., DELHI MARKET	SCALE	2:1 & 1:1
PARTY'S DRAWING No.	AS PER SEC No 2761 AND SPECIFICATION	WEIGHT kg/m	0.872
ALLOY & TEMPER	HE9 WP	SECTION No.	22010
DESCRIPTION	MISCELLANEOUS TUBE	DRAWING No.	22010