

P-3706

2803

22018

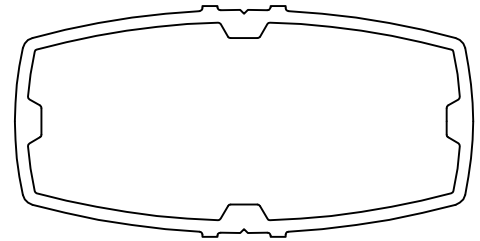

1:1

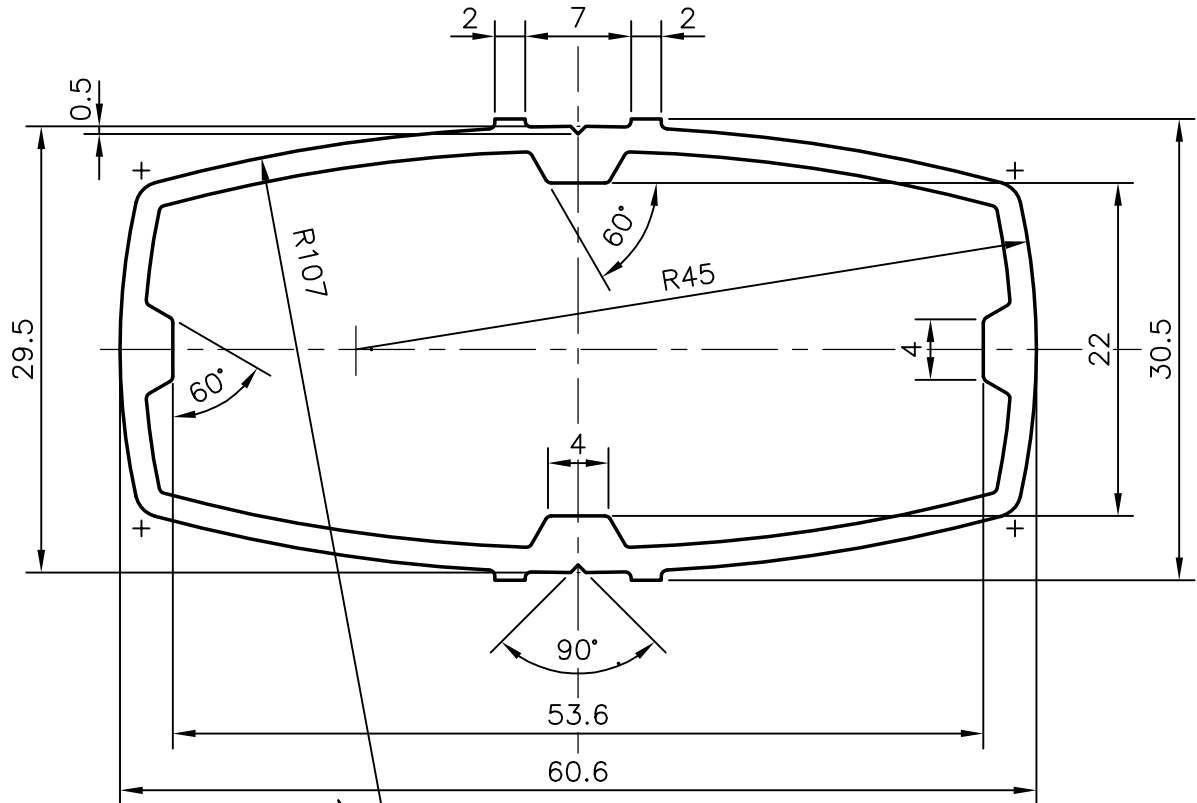

GENERAL WALL THICKNESS:- 1.62 mm.
+ = 1.75 RADIUS (4)

JINDAL ALUMINIUM LTD.

BANGALORE-560073

	NAME	DATE
DRAWN	RAGHAVENDRA	29-12-01
CHECKED		
APPROVED		
SCALE	2:1	
WEIGHT kg/m	0.800	
SECTION No.	22018	
DRAWING No.	22018	

1. ALL DIMENSIONS ARE IN mm.
2. ROUND OFF ALL SHARP CORNERS WITH 0.4 mm.
3. TOLERANCES WILL BE AS PER IS: 6477-1983 ,UNLESS OTHERWISE SPECIFIED

PARTY'S NAME	GENERAL CATEGORY,DELHI MARKET
PARTY'S DRAWING No.	HEAVIER SECTION OF 2749
ALLOY & TEMPER	HE9 WP
LENGTH	3658 mm. & 4572 mm.
DESCRIPTION	DISPLAY SECTION