

P-5278

22048

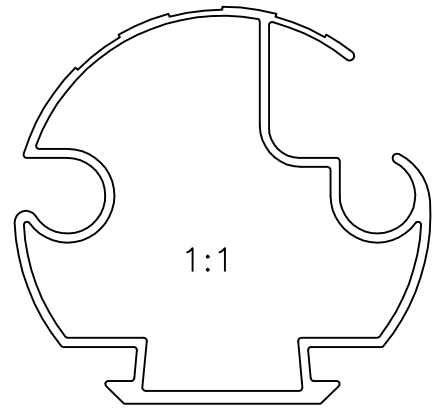

**NOTE:-**

1. GENERAL WALL THICKNESS 1.20mm
2. F=FULL RADIUS

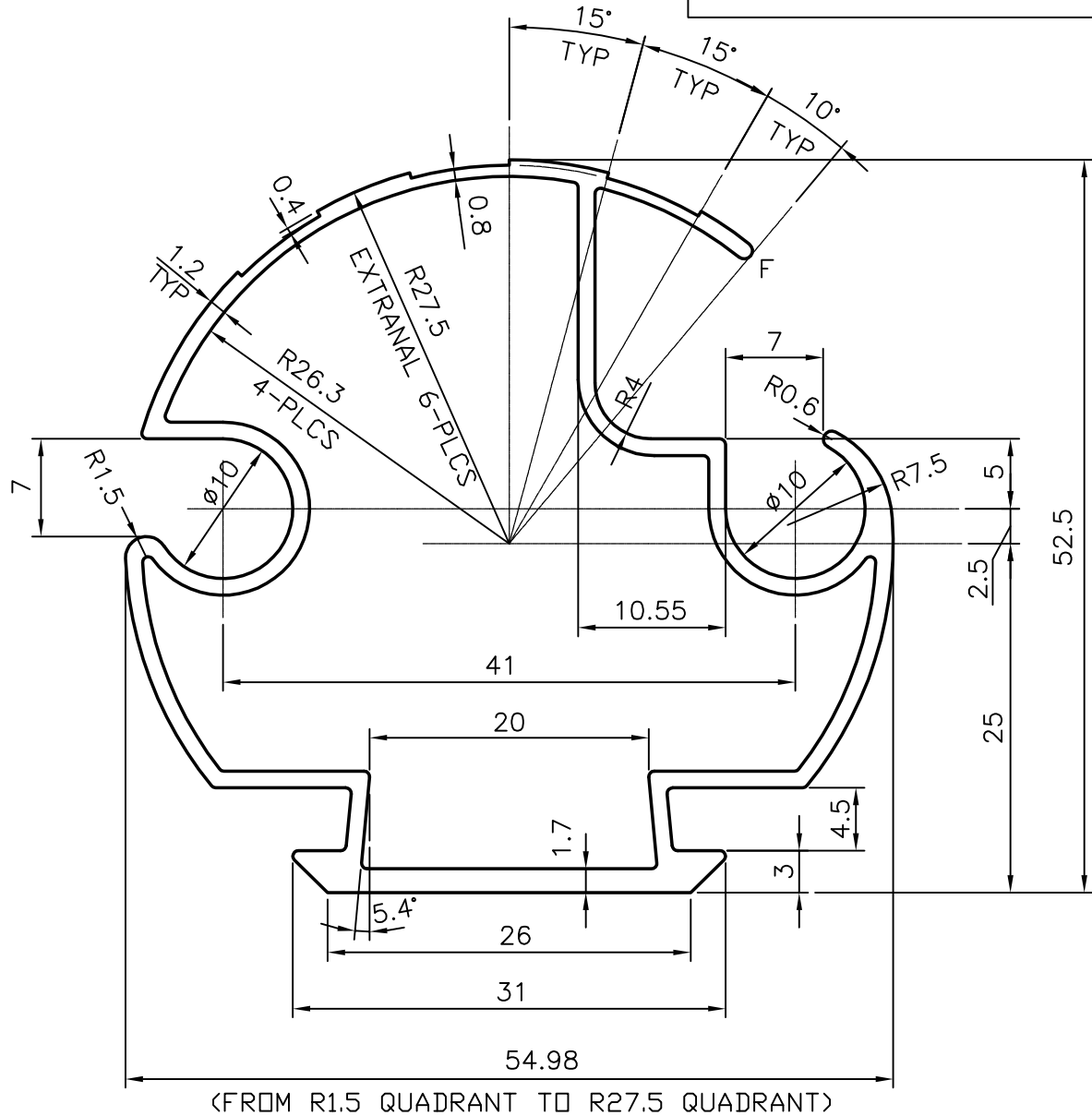

**JINDAL ALUMINIUM LTD.**  
 BANGALORE-560073 (INDIA)

	NAME	DATE
DRAWN	MALINGAPPA	14-02-2005
CHECKED		
APPROVED		

1. ALL DIMENSIONS ARE IN mm.
2. ROUND OFF ALL SHARP CORNERS WITH 0.40 mm.
3. TOLERANCES WILL BE AS PER IS: 6477-1983 UNLESS OTHERWISE SPECIFIED

SCALE	1:1
AREA mm <sup>2</sup>	300.378
PERIMETER mm.	269.165
WEIGHT kg/m	0.811

PARTY'S NAME	GENERAL CATEGORY, DELHI MARKET.
PARTY'S DRAWING No.	LIGHTER OF SECTION NO. 22010
ALLOY & TEMPER	HE9 WP
DESCRIPTION	VENETIAN BLIND SECTION

DRAWING No.	SECTION No.
P-5278	-
22048	22048