

P-4605

X302

22058

GENERAL WALL THICKNESS = 1.00mm

F = FULL RADIUS (10)

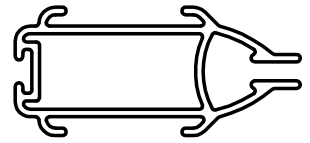

SCALE 1:1

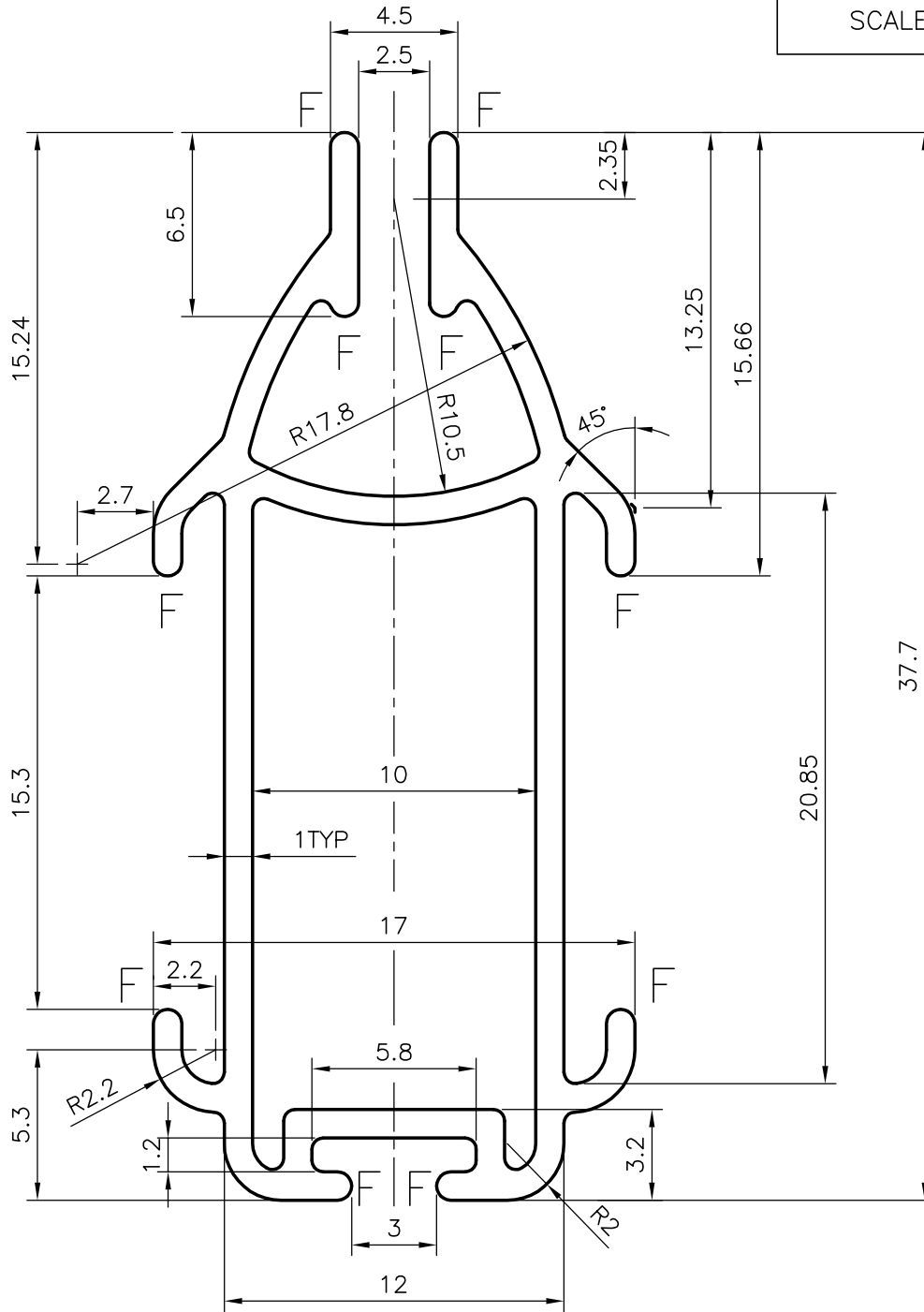

SYMBOL OF QUALITY
AN ISO 9002 COMPANY

JINDAL ALUMINIUM LTD.
BANGALORE-560073 (INDIA)

	NAME	DATE
DRAWN	RAGHAVENDRA	03-12-2003
CHECKED		
APPROVED		

1. ALL DIMENSIONS ARE IN mm.
2. ROUND OFF ALL SHARP CORNERS WITH 0.40 mm.
3. TOLERANCES WILL BE AS PER IS: 6477-1983 UNLESS OTHERWISE SPECIFIED

SCALE	4:1 & 1:1
AREA mm ²	126.92
PERIMETER mm.	168.30
WEIGHT kg/m	0.343

PARTY'S NAME	LOUVERLINE BLINDS,. BANGALORE
PARTY'S DRAWING No.	AS PER SAMPLE
ALLOY & TEMPER	HE9 WP
DESCRIPTION	MISC. HOLLOW

DRAWING No.	SECTION No.
P-4605	-
X302	X302
22058	22058