

P-5453-1

S1496

22059

UNSPECIFIED RADIUS WILL BE R1.20mm
 F = FULL RADII (6 PLACES)
 V = "V" GROOVE 0.38x90° (2 PLACES)

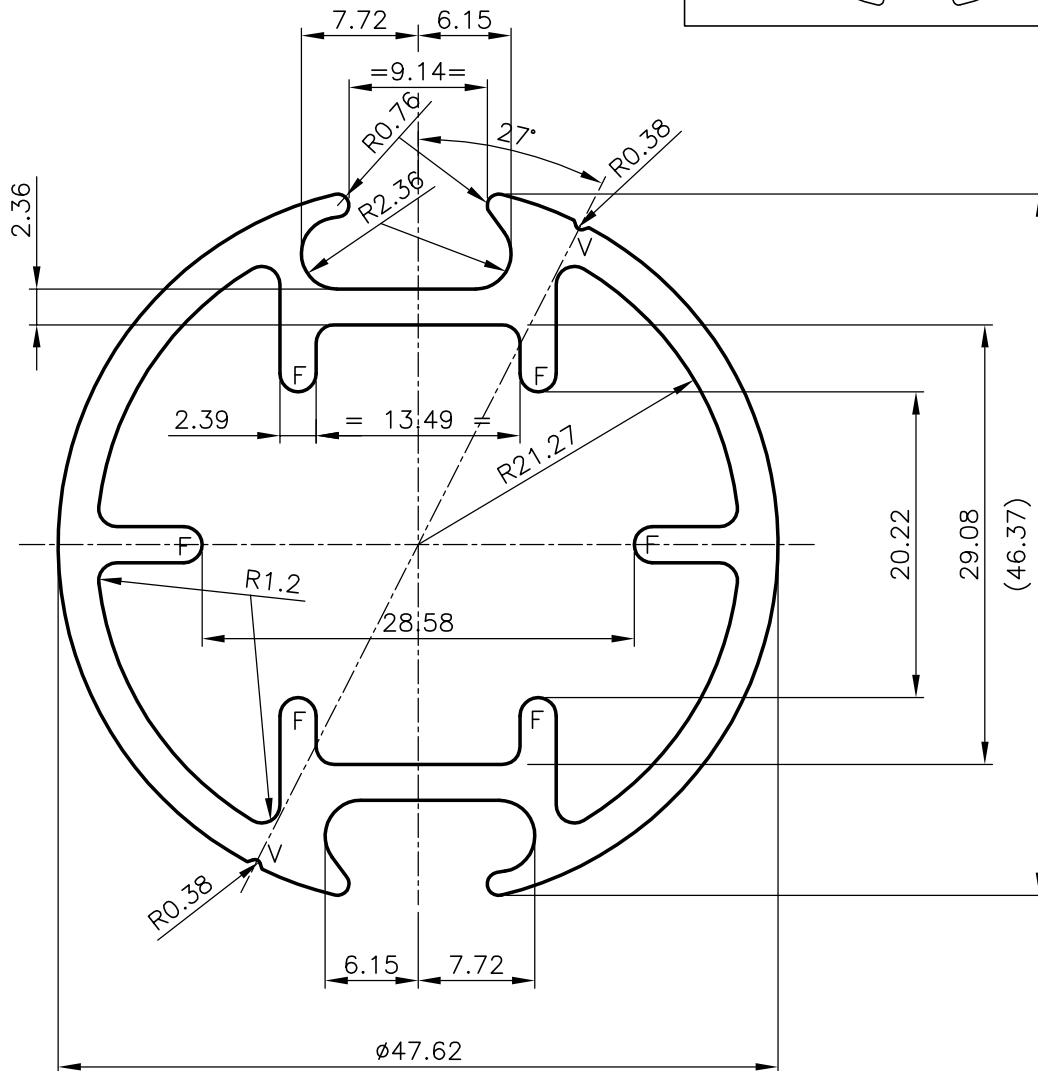
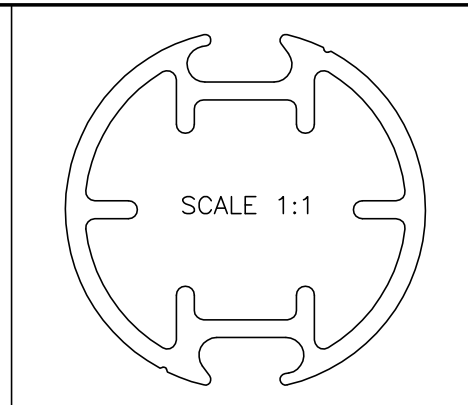

JINDAL ALUMINIUM LTD.
 BANGALORE-560073 (INDIA)

	NAME	DATE
DRAWN	RAGHAVENDRA	02-05-2005
CHECKED		
APPROVED		
SCALE		2:1
AREA mm ²		498.547
PERIMETER mm.		183.681
WEIGHT kg/m		1.346
DRAWING No.	SECTION No.	
P-5453-1	-	
S1496	S1496	
22059	22059	

1. ALL DIMENSIONS ARE IN mm. 2. ROUND OFF ALL SHARP CORNERS WITH 0.40 mm. 3. TOLERANCES WILL BE AS PER IS:6477-1983 UNLESS OTHERWISE SPECIFIED	
PARTY'S NAME	WALL TRACTS INDIA (P) LTD., BANGALORE
PARTY'S DRAWING No.	AS PER SAMPLE
ALLOY & TEMPER	6063 T6
DESCRIPTION	VENETION BLIND