

P-5610-1  
X401  
22076

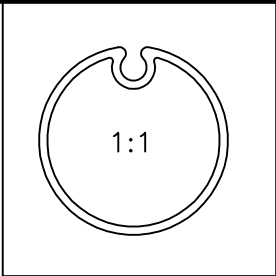

GENERAL WALL THICKNESS = 1.10 mm  
F = FULL RADIUS (2 PLACES)

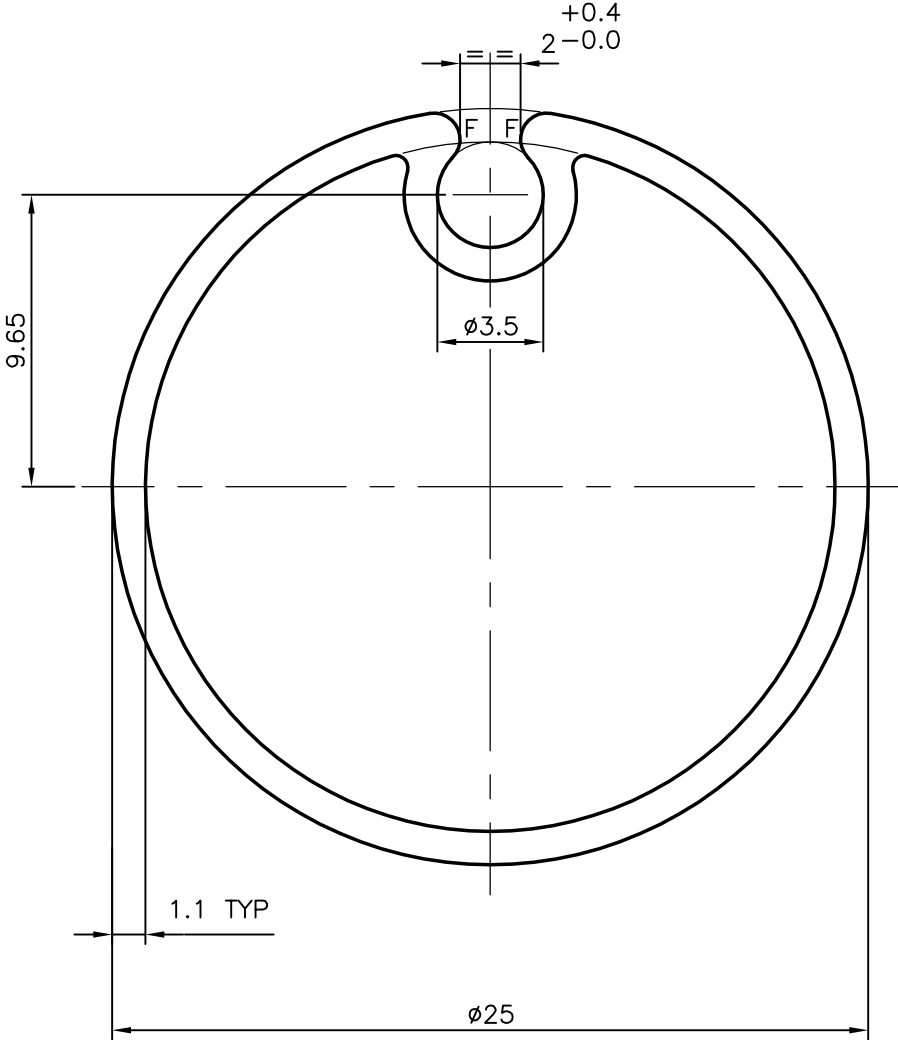

**JINDAL ALUMINIUM LTD.**  
BANGALORE-560073 (INDIA)

	NAME	DATE
DRAWN	MALINGAPPA	05-07-2005
CHECKED		
APPROVED		

1. ALL DIMENSIONS ARE IN mm.
2. ROUND OFF ALL SHARP CORNERS WITH 0.40 mm.
3. TOLERANCES WILL BE AS PER IS:6477-1983 UNLESS OTHERWISE SPECIFIED

SCALE	4:1
AREA mm <sup>2</sup>	92.202
PERIMETER mm.	87.131
WEIGHT kg/m	0.249

PARTY'S NAME	MC WINDOW SYSTEM, BANGALORE
PARTY'S DRAWING No.	AS PER DRAWING
ALLOY & TEMPER	HE9 WP
DESCRIPTION	VENETIAN BLIND - ROLLER SYSTEM

DRAWING No.	
P-5610-1	-
X401	X401
22076	22076