

P-6679

S1856

22079

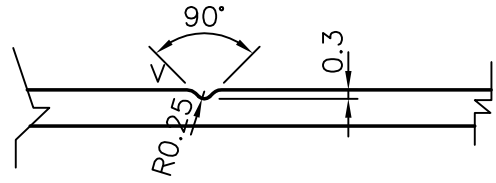

DETAIL V GROOVE

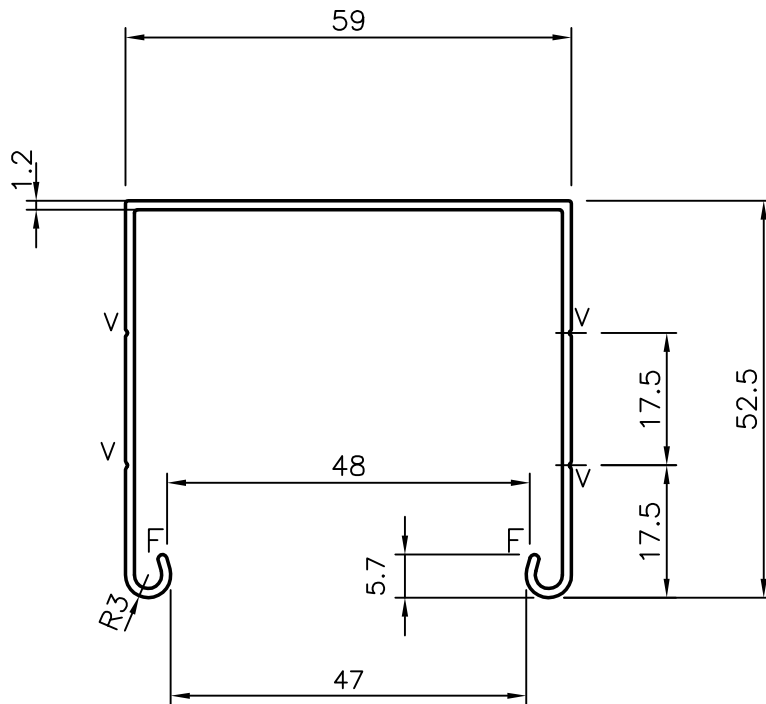

GENERAL WALL THICKNESS 1.2mm

F = FULL RADIUS 2

V = 0.3x90°xR0.25 (4 PLACE)



SYMBOL OF QUALITY
AN ISO 9001 COMPANY

JINDAL ALUMINIUM LTD.
BANGALORE-560073 (INDIA)

	NAME	DATE
DRAWN	J.P.KAUSHIK	20-09-2006
CHECKED		
APPROVED		

1. ALL DIMENSIONS ARE IN mm.
2. ROUND OFF ALL SHARP CORNERS WITH 0.40 mm.
3. TOLERANCES WILL BE AS PER IS:3965-1981 UNLESS OTHERWISE SPECIFIED

SCALE	1:1
AREA mm ²	210.628
PERIMETER mm.	354.031
WEIGHT kg/m	0.569

PARTY'S NAME	MAC VENETIANS, NEW DELHI	DRAWING No.	P-6679	SECTION No.	
PARTY'S DRAWING No.	AS PER DRAWING		S1856		S1856
ALLOY & TEMPER	HE9 WP		22079		22079
DESCRIPTION	MISCELLANEOUS SECTION				