

P-5857

S1593

22082

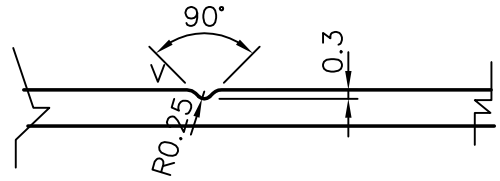

DETAIL V GROOVE

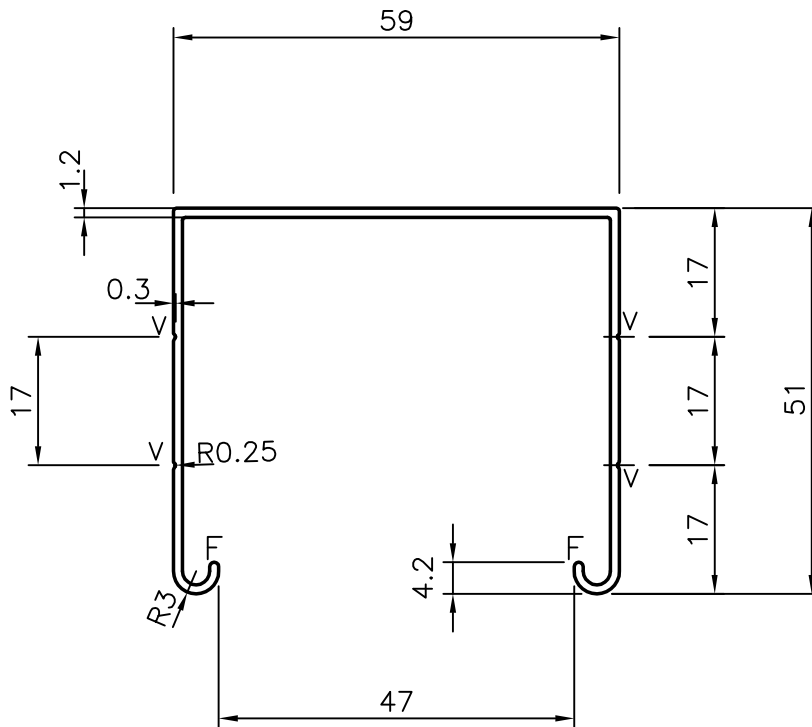

GENERAL WALL THICKNESS 1.2mm

F = FULL RADIUS 2

V = 0.3x90°xR0.25 (4 PLACE)



SYMBOL OF QUALITY
AN ISO 9001 COMPANY

JINDAL ALUMINIUM LTD.
BANGALORE-560073 (INDIA)

	NAME	DATE
DRAWN	J.P.KAUSHIK	08-09-2005
CHECKED		
APPROVED		

1. ALL DIMENSIONS ARE IN mm.
2. ROUND OFF ALL SHARP CORNERS WITH 0.40 mm.
3. TOLERANCES WILL BE AS PER IS: 6477-1983 UNLESS OTHERWISE SPECIFIED

SCALE	1:1
AREA mm ²	203.161
PERIMETER mm.	341.613
WEIGHT kg/m	0.549

PARTY'S NAME	MAC VENETIANS, NEW DELHI
PARTY'S DRAWING No.	AS PER DRAWING
ALLOY & TEMPER	HE9 WP
DESCRIPTION	MISCELLANEOUS SECTION

DRAWING No.	SECTION No.
P-5857	-
S1593	S1593
22082	22082