

P-7641-1  
22085

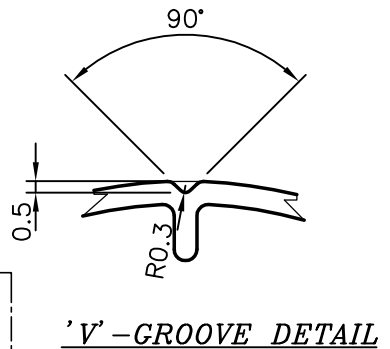

- NOTE:-
1. UNSPECIFIED WALL THICKNESS 1.0 mm
  2. F = FULL RADIUS (4 PLACES)
  3. s = R0.50 mm (11 PLACES)

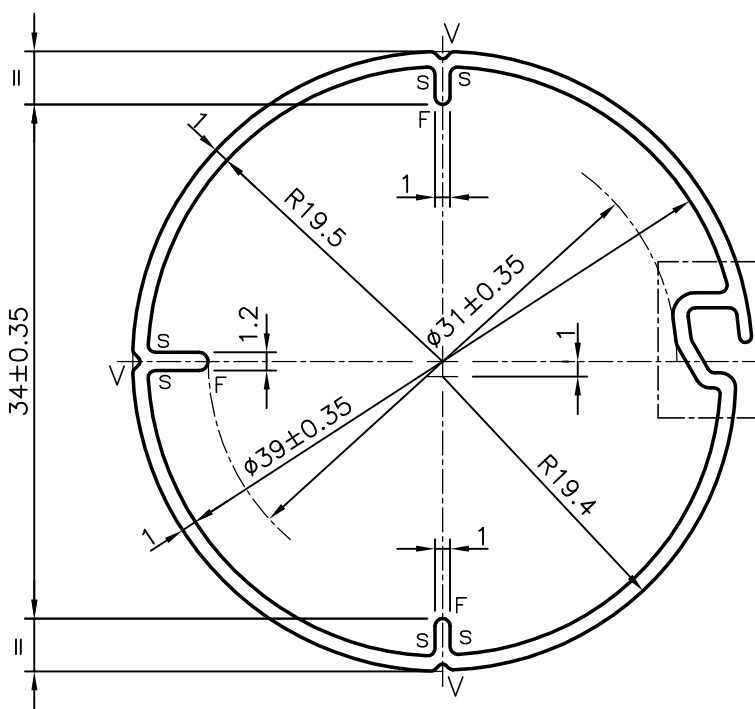
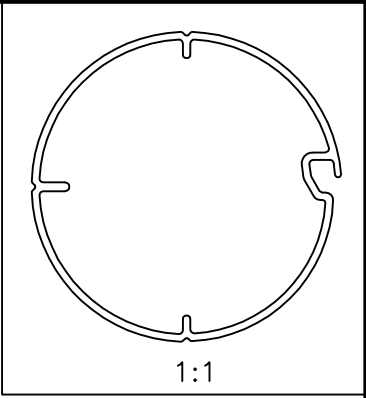
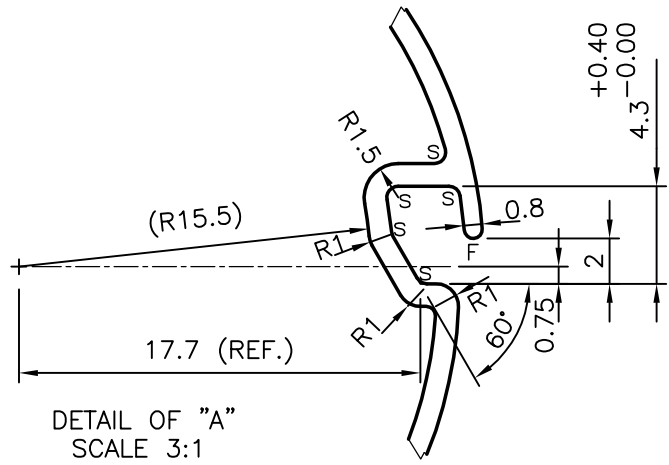

**JINDAL ALUMINIUM LTD.**  
BANGALORE-560073 (INDIA)

	NAME	DATE
DRAWN	J.P.KAUSHIK	28-12-2007
CHECKED		
APPROVED		

1. ALL DIMENSIONS ARE IN mm.
2. ROUND OFF ALL SHARP CORNERS WITH 0.40 mm.
3. TOLERANCES WILL BE AS PER IS:6477-1983 UNLESS OTHERWISE SPECIFIED

SCALE	2:1
AREA mm <sup>2</sup>	140.579
PERIMETER mm.	138.481
WEIGHT kg/m	0.380

PARTY'S NAME	N.B.T EXPORT PVT. LTD.,MUMBAI
PARTY'S DRAWING No.	20101-RD8A-0000
ALLOY & TEMPER	6063 T5
DESCRIPTION	VENETIAN BLIND SECTION

DRAWING No.	SECTION No.
P-7641-1	-
22085	22085