

P-7215-3

S1976

22100

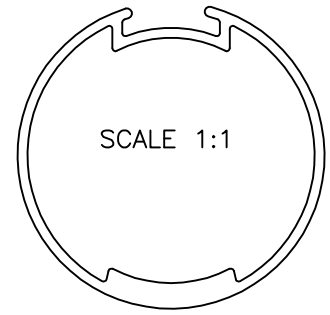

SCALE 1:1

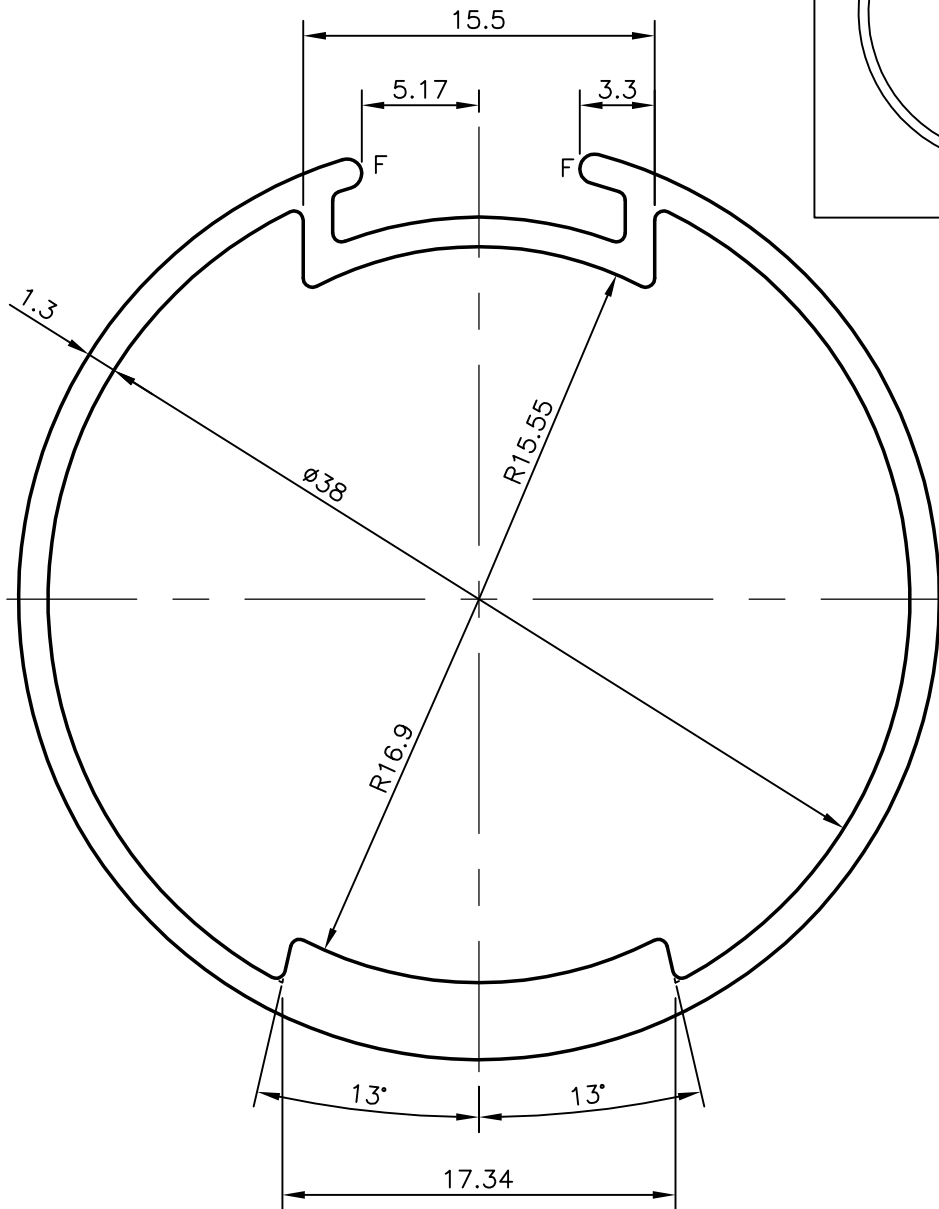

NOTE:-

1. GENERAL WALL THICKNESS = 1.30 mm
2. F = FULL RADIUS (2 PLACES)
3. PLASTIC COMPONENT SHOULD MATCH PROPERLY WITH PROFILE



SYMBOL OF QUALITY
AN ISO 9001 COMPANY

JINDAL ALUMINIUM LTD.
BANGALORE-560073 (INDIA)

	NAME	DATE
DRAWN	PRASANN.H	07-06-2007
CHECKED		
APPROVED		
SCALE		3:1
AREA mm ²		211.554
PERIMETER mm.		139.566
WEIGHT kg/m		0.571
DRAWING No.	SECTION No.	
P-7215-3	-	
S1976	S1976	
22100	22100	

1. ALL DIMENSIONS ARE IN mm.
2. ROUND OFF ALL SHARP CORNERS WITH 0.40 mm.
3. TOLERANCES WILL BE AS PER IS:6477-1983 UNLESS OTHERWISE SPECIFIED

PARTY'S NAME	GTC INDUSTRIES, MUMBAI
PARTY'S DRAWING No.	AS PER DRAWING
ALLOY & TEMPER	HE9 WP
DESCRIPTION	VENETIAN BLIND