

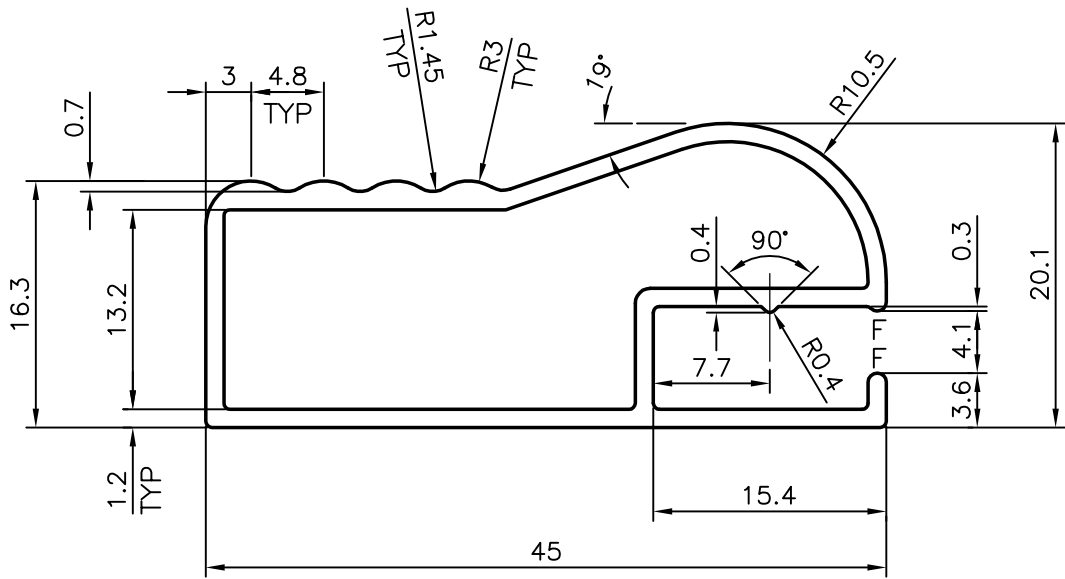

P-4692
4948
22116

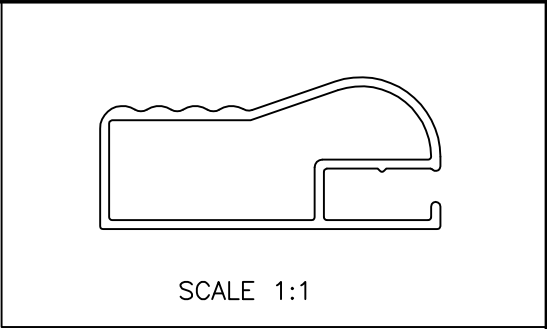

GENERAL WALL THICKNESS:- 1.2 mm
 F = FULL RADIUS (2)

 SYMBOL OF QUALITY AN ISO 9002 COMPANY	JINDAL ALUMINIUM LTD. BANGALORE-560073 (INDIA)	NAME		DATE
		DRAWN	RAGHAVENDRA	19-03-2004
1. ALL DIMENSIONS ARE IN mm. 2. ROUND OFF ALL SHARP CORNERS WITH 0.40 mm. 3. TOLERANCES WILL BE AS PER BS:1474-1987 UNLESS OTHERWISE SPECIFIED		CHECKED		
		APPROVED		
PARTY'S NAME SYDNEY ALUMINIUM		SCALE		2:1
		AREA mm ²		169.364
PARTY'S DRAWING No. AS PER SAMPLE		PERIMETER mm.		156.876
		WEIGHT kg/m		0.457
ALLOY & TEMPER 6063 T6		DRAWING No.		SECTION No.
		P-4692		-
DESCRIPTION KITCHEN CABINET SECTION		4948		4948
		22116		22116